

FD10,15,18T-MW
 FD10,15,18T-MG
 FG(L)10,15,18T-MG
 FG(L)10,15,18T-MW

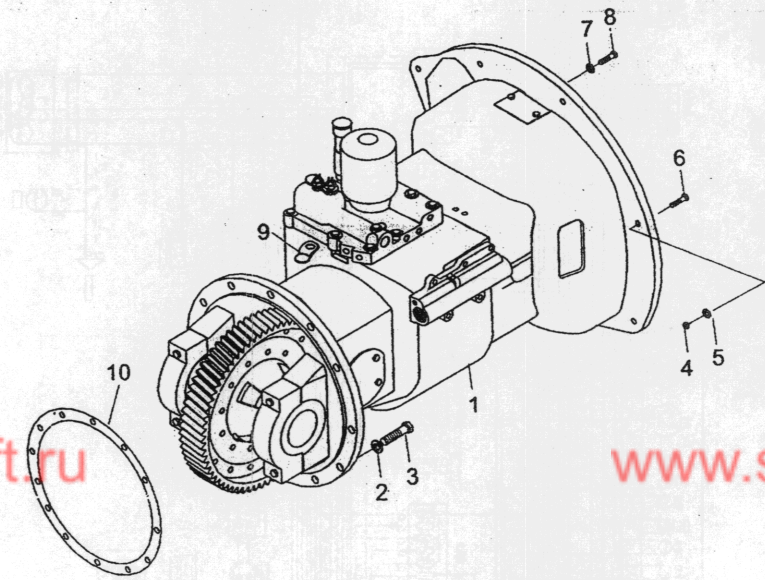

序号 Item No	图号 Part No	零部件名称 Description	件数 Q'ty	备注 Remark
01	M1543400000	Drive unit 液力变速箱总成	1	
02	GB93-87	Washer,lock 垫圈12	12	
03	GB5785-86	Bolt 螺栓M12×1.25×40	12	
04	GB6170-86	Nut 螺母M10	1	
05	GB93-87	Washer 垫圈10	1	
-	GB97.1-85	Washer 垫圈10-140HV	1	
06	GB5782-86	Bolt 螺栓M10×60	1	
07	GB93-87	Washer,lock 垫圈10	8	
08	GB5785-86	Bolt 螺栓M10×1.25×35	7	
-	GB5782-86	Bolt 螺栓M10×35	8	
09	M3043400001	Clip 管夹片	1	
10	M3043400002	Packing 垫片	1	



传动装置安装(液力式)/DRIVE UNIT MOUNT(TOR-CON TYPE)

序号 Item No	图号 Part No	零部件名称 Description	件数 Q'ty	备注 Remark
01	YDS30.035	Case,tor-con	1	变矩器壳体
02	YDS30.909	Cup	1	加油口盖
03	YDS30.103	Plug	1	螺塞1/2"
04	YJH265	Tor-con ass'y	1	变矩器总成
05	YDS30.906	Charging pump ass'y	1	供油泵总成
06	YDS30.100	Gasket	1	衬垫
07	GB894.1-86	Snap ring	1	挡圈35
08	YDS30.808	Strainer	1	滤油器
09	GB1235-76	O-ring	1	O形圈35×3.1
10	YDS30.104	Plug	2	内六角螺塞1/4"
11	GB1235-76	O-ring	1	O形圈28×3.5
12	YDS30.038	Gasket	1	垫片
13	GB5783-86	Bolt	1	螺栓M10×1.25×30
14	GB5783-86	Bolt	3	螺栓M10×1.25×50
15	GB5783-86	Bolt	1	螺栓M10×1.25×55
16	GB5783-86	Bolt	4	螺栓M10×1.25×75
17	GB93-87	Washer	9	垫圈10
18	GB119-86	Pin	2	销B12×20
19	GB1235-76	O-ring	1	O形圈15×2.4
20	YDS25.001	Case,mission	1	壳体
21	YDS25.002	Cap,bearing	2	轴承座
22	YDS30.089	Bolt	4	螺栓
23	YDS25.003	Washer,lock	4	锁片
24	YDS18.901	Clutch,hydraulic	1	离合器总成
25	YDS30.025	Shaft,idler	1	惰性轴
26	GB276-94	Bearing	1	轴承6206-2RS

FD10,15,18T-MW
 FD10,15,18T-MG
 FG(L)10,15,18T-MG
 FG(L)10,15,18T-MW

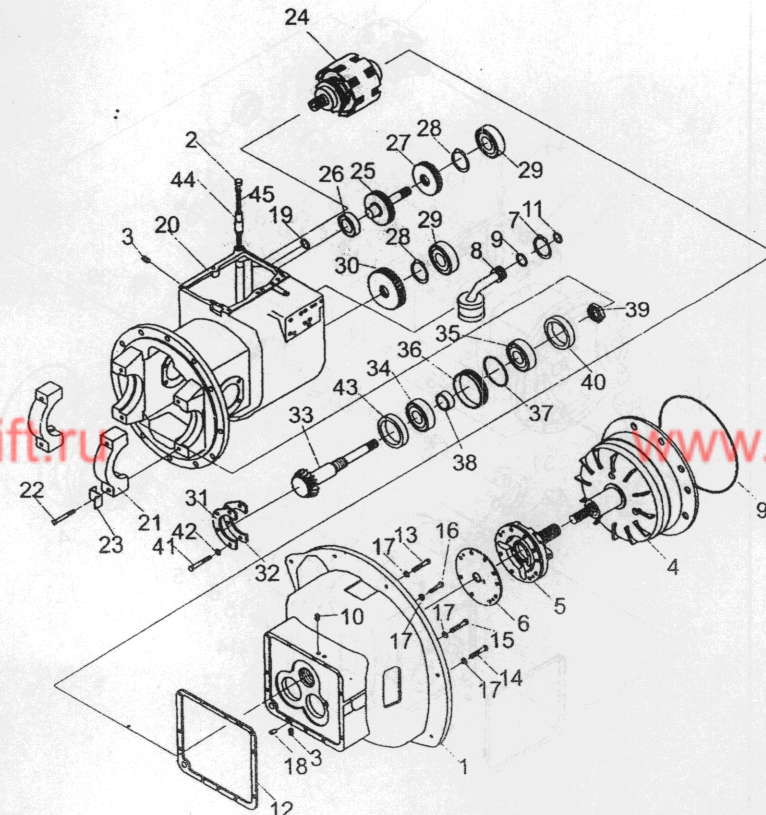

FD10,15,18T-MW
 FD10,15,18T-MG
 FG(L)10,15,18T-MG
 FG(L)10,15,18T-MW

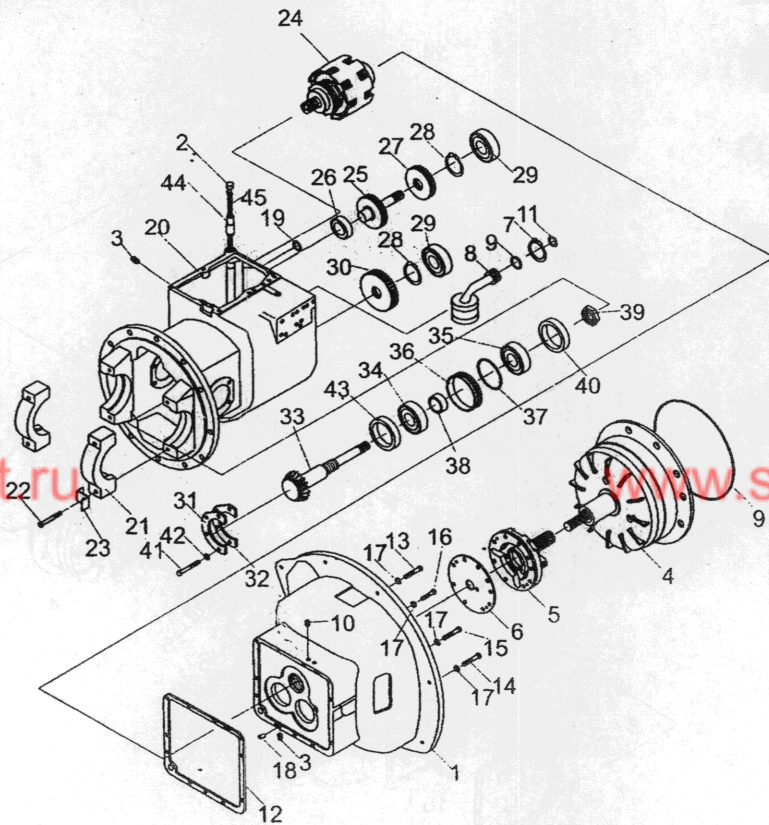

序号 Item No	图号 Part No	零部件名称 Description	件数 Q'ty	备注 Remark
27	YDS30.037	Gear, idler	惰轮	1
28	GB893.1-86	Snap ring	挡圈24	2
29	GB276-94	Bearing	轴承6207	2
30	YDS30.036	Gear, output	输出齿轮	1
31	YDS30.021	Plate, bearing support	支承片	1
32	YDS30.022(δ=0.1)	Shim	垫片	按需
-	YDS30.022(δ=0.2)	Shim	垫片	按需
-	YDS30.022(δ=0.5)	Shim	垫片	按需
33	YDS18.003	Shaft, output	输出轴	1
34	GB279-94	Bearing	轴承32208	2
35	GB279-94	Bearing	轴承30208	1
36	YDS30.023	Retainer, oil seal	油封保持架	1
37	GB1325-76	O-ring	O形圈80×3.1	1
38	12163-82131	Seal, oil	油封	1
39	YDS30.024	Nut	螺母	1
40	YDS30.019(δ=0.1)	Shim	垫	按需
-	YDS30.019(δ=0.2)	Shim	垫	按需
-	YDS30.019(δ=0.5)	Shim	垫	按需
41	GB5783-86	Bolt	螺栓M8×20	4
42	GB93-87	Washer	垫圈8	15
43	YDS30.020	Collar	轴环	1
44	YDS30.049	Pipe oil fill	加油管	1
45	-	Gasket	衬垫	1



传动装置(盖和微动阀)/DRIVE UNIT(COVER&INCHING VALVE)

序号 Item No	图号 Part No	零部件名称 Description	件数 Q'ty	备注 Remark
01	YDS30.066	Cover,case	壳体盖	1
02	YDS30.033	Arm,shift	变速臂	1
03	GB879-86	Pin,lock	销6×32	1
04	YDS30.032	Shaft,shift arm	变速臂轴	1
05	GB1235-76	O-ring	O形圈20×2.4	1
06	GB1099-79	Key,woodruf	半圆键5×19	1
07	YDS30.068	Bolt	螺栓	1
08	Q/301B 202-86	Washer	密封圈	1
09	YDS30.034	Plug	塞子	1
10	JK208	Switch	倒车灯开关	2
11	14×24×2	Shim	垫片	2
12	YDS30.048	Nipple	管接头	1
13	YDS5.904	Filter,oil	滤油器	1
14	GB879-86	Pin,lock	弹性圆柱销4×25	1
15	YDS30.052	Piston	活塞	1
16	YDS30.050	Spring	弹簧	1
17	YDS30.051	Cup	安全阀盖	1
18	Q/301B 202-86	Washer	密封圈	1
19	YDS30.103	Plug	螺塞1/8"	4
20	YDS30.102	Plug	螺塞1/4"	6
21	YDS30.904	Control ass'y	控制阀总成	1
22	YDS30.065	Gasket	垫片	1
23	GB5783-86	Bolt	螺栓M8×35	2
24	GB5783-86	Bolt	螺栓M8×55	2
25	GB5783-86	Bolt	螺栓M8×50	4
26	GB93-87	Shim	垫圈8	11

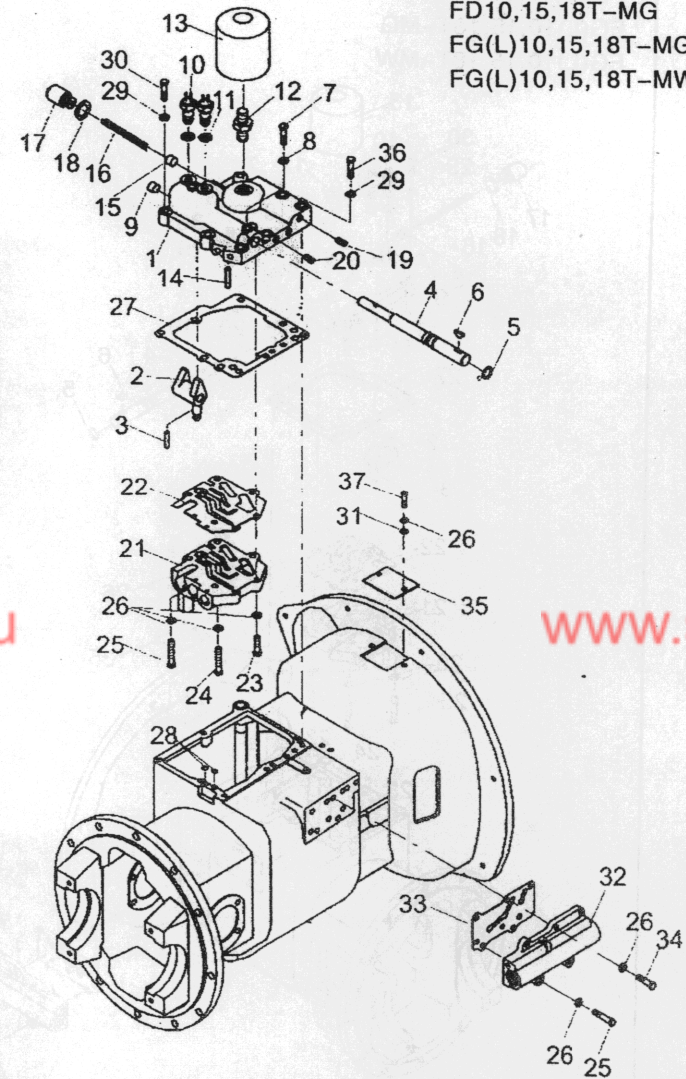

FD10,15,18T-MW
 FD10,15,18T-MG
 FG(L)10,15,18T-MG
 FG(L)10,15,18T-MW



FD10,15,18T-MW
 FD10,15,18T-MG
 FG(L)10,15,18T-MG
 FG(L)10,15,18T-MW

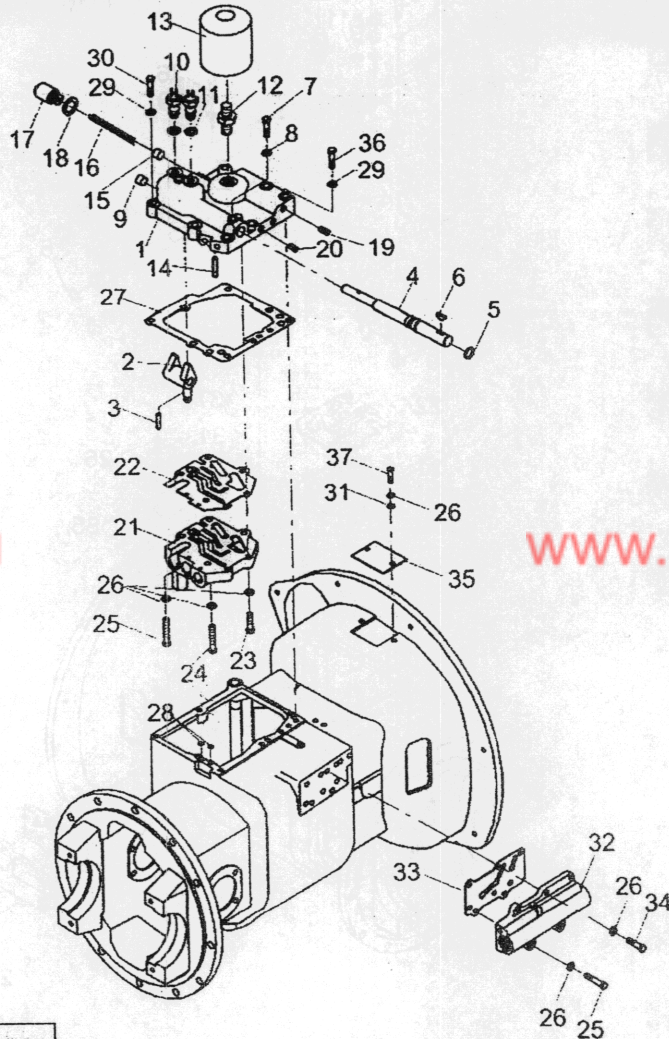

序号 Item No	图号 Part No	零部件名称 Description	件数 Q'ty	备注 Remark
27	YDS30.067	Gasket	垫片	1
28	GB1235-76	O-ring	O形圈9×1.9	2
29	GB93-87	Washer,lock	垫圈10	8
30	GB5783-86	Bolt	螺栓M10×1.25×55	2
31	GB93-87	Shim	垫圈8	2
32	YDS30.910	Inching valve ass'y	微动阀总成	1
33	YDS30.047	Shim	衬垫	1
34	GB5783-86	Bolt	螺栓M8×25	4
35	YDS30.112	Cover,tor-con	变距器盖	1
36	GB5783-86	Bolt	螺栓M10×1.25×40	6
37	GB5783-86	Bolt	螺栓M8×12	2



供油泵(液力式)/CHARGING PUMP(TOR-CON TYPE)

序号 Item No	图号 Part No	零部件名称 Description	件数 Q'ty	备注 Remark
A	YDS30.906	Charging pump ass'y	1	供油泵总成
01	YDS30.091	Case,pump	1	泵体
02	YDS30.092	Bushing	1	衬套
03	JB982-77	Washer	2	衬垫
04	AH2847R	Seal,oil	1	油封
05	GB3452.1-92	Snap O-ring	1	"O"形密封圈
06	YDS30.095	Support,starter	1	定子
07	GB119-86	Pin	2	圆柱销6×16
08	YDS30.096	Gear,drive	1	主动齿轮
09	YDS30.097	Bushing	1	衬套
10	YDS30.098	Gear,driven	1	被动齿轮
11	GB5783-86	Bolt	1	螺栓M8×25
12	GB5783-86	Bolt	1	螺栓M8×35

FD10,15,18T-MW
 FD10,15,18T-MG
 FG(L)10,15,18T-MG
 FG(L)10,15,18T-MW

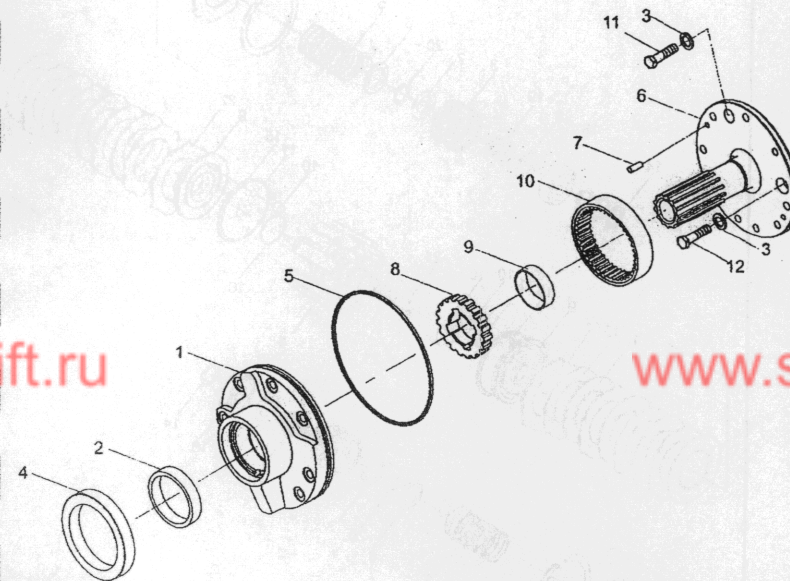

FD10,15,18T-MW
 FD10,15,18T-MG
 FG(L)10,15,18T-MG
 FG(L)10,15,18T-MW

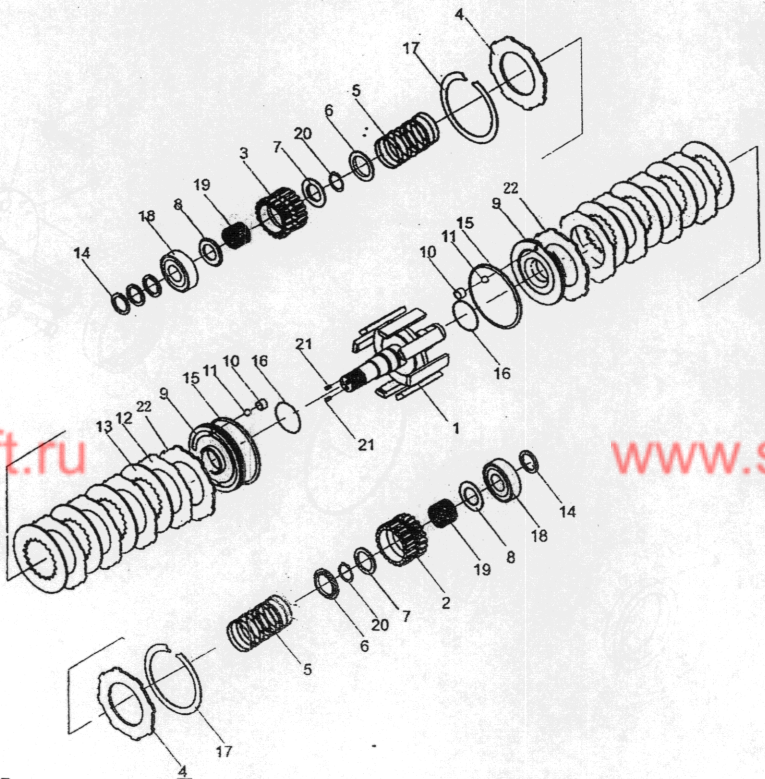

序号 Item No	图号 Part No	零部件名称 Description	件数 Q'ty	备注 Remark
A	YDS30.901	Clutch,hydraulic	离合器总成	1
01	YDS30.802	Shift,input	输入轴总成	1
02	YDS30.007	Gear,reverse	倒车挡齿轮	1
03	YDS30.008	Gear,forward	前进挡齿轮	1
04	YDS18.002	Plate,end	端板	2
05	YDS30.009	Spring,return	回程弹簧	2
06	YDS30.010	Seat,spring	弹簧座	2
07	YDS30.011	Ring,thrust	止推环A	2
08	YDS30.012	Ring,thrust	止推环B	2
09	YDS30.005	Piston	活塞	1
10	YDS30.006	Plug	塞	1
11	GB308-89	Ball,steel	钢球1/8"	1
12	11243-82141	Plate,friction	摩擦片	6
13	123S3-82111	Plate,separator	隔片	6
14	YDS30.015	Ring,seal	密封环A	4
15	YDS30.016	Ring,seal	密封环B	2
16	GB1235-76	O-ring	O形圈33.7×3.5	2
17	YDS30.017	Snap,ring	卡环	2
18	GB276-94	Bearing	轴承206	2
19	GB5846-86	Bearing,needle	滚珠轴承	2
20	GB894.1-86	Snap,ring	挡圈40	2
21	GB77-85	Plug	螺钉M8×8	2
22	YDS18.001	Disc Shaped Plate	碟形板	2



序号 Item No	图号 Part No	零部件名称 Description	件数 Q'ty	备注 Remark
A	YDS30.907	Control valve ass'y	1	控制阀总成
01	YDS30.053	Body, valve	1	阀体
02	YDS30.054	Selector	1	滑阀
03	YDS30.055	Plug	1	油塞
04	YDS30.056	Spring	1	弹簧
05	GB308-89	Ball	1	钢球13/32"
06	YDS30.057	Piston	1	活塞
07	YDS30.058	Spring	1	弹簧
08	YDS30.059	Spring	1	弹簧
09	YDS30.060	Plug	1	塞
10	GB879-86	Pin, lock	1	弹性圆柱销4×35
11	YDS30.061	Spool	1	卷轴
12	YDS30.062	Spring	1	弹簧
13	YDS30.063	Spring	1	弹簧
14	YDS30.064	Plug	1	塞
15	GB879-86	Pin, lock	1	弹性圆柱销4×40

FD10,15,18T-MW
 FD10,15,18T-MG
 FG(L)10,15,18T-MG
 FG(L)10,15,18T-MW

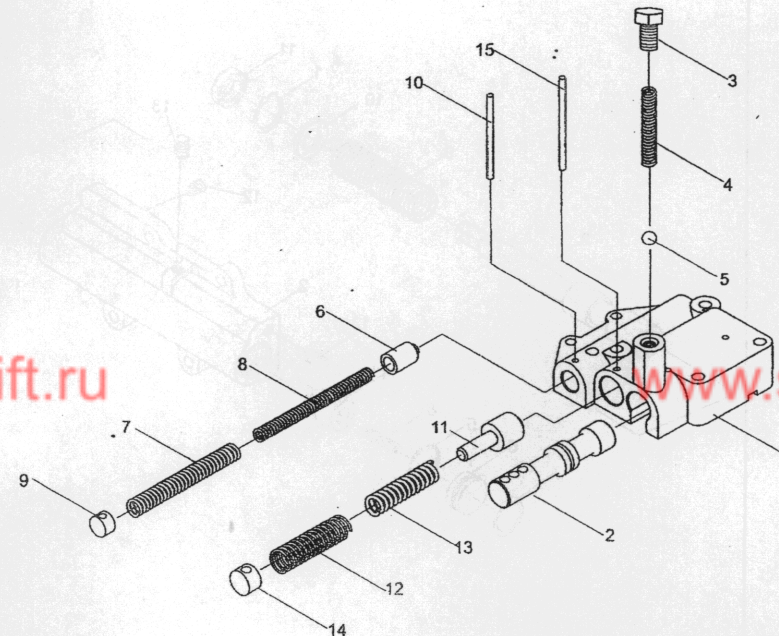

微动阀(液力式)/INCHING VAVLE(TOR-CON TYPE)

FD10,15,18T-MW
 FD10,15,18T-MG
 FG(L)10,15,18T-MG
 FG(L)10,15,18T-MW

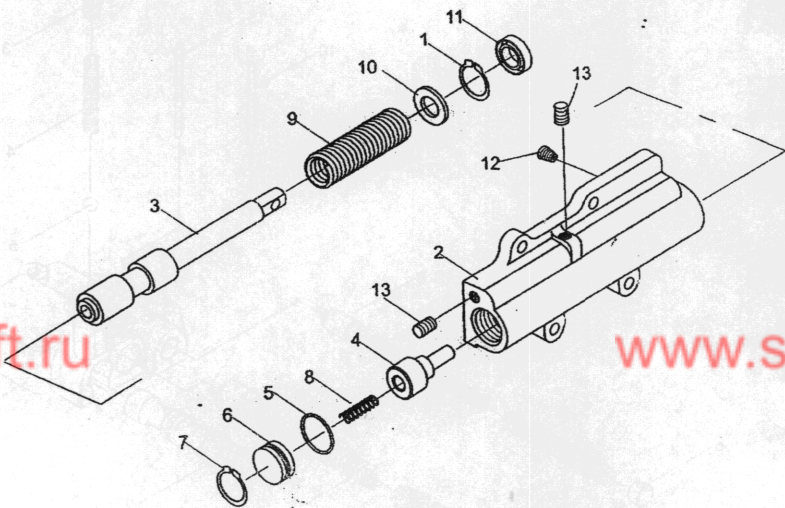

序号 Item No	图号 Part No	零部件名称 Description	件数 Q'ty	备注 Remark
A	YDS30.903	Inching vavle ass'y	1	微动阀总成
01	GB893.1-86	Snap ring	1	挡圈30
02	YDS30.120	Body,vavle	1	阀体
03	YDS30.121	Spool	1	卷杆
04	YDS30.122	Plunger	1	滑阀
05	GB3452.1-92	O-ring	1	O形圈23.6×2.65
06	YDS30.123	Seal,oil	1	油封
07	GB893.1-86	Snap ring	1	挡圈28
08	YDS30.044	Spring	1	微动弹簧
09	YDS30.043	Spring	1	微动弹簧
10	YDS30.124	Spacer	1	垫块
11	AE0687A0	Seal,oil	1	油封
12	YQX100.092	Plug,choke	1	油塞
13	YDS30.102	Plug	2	螺塞ZG1/8"

