

0003

汽缸盖  
CYLINDER HEAD

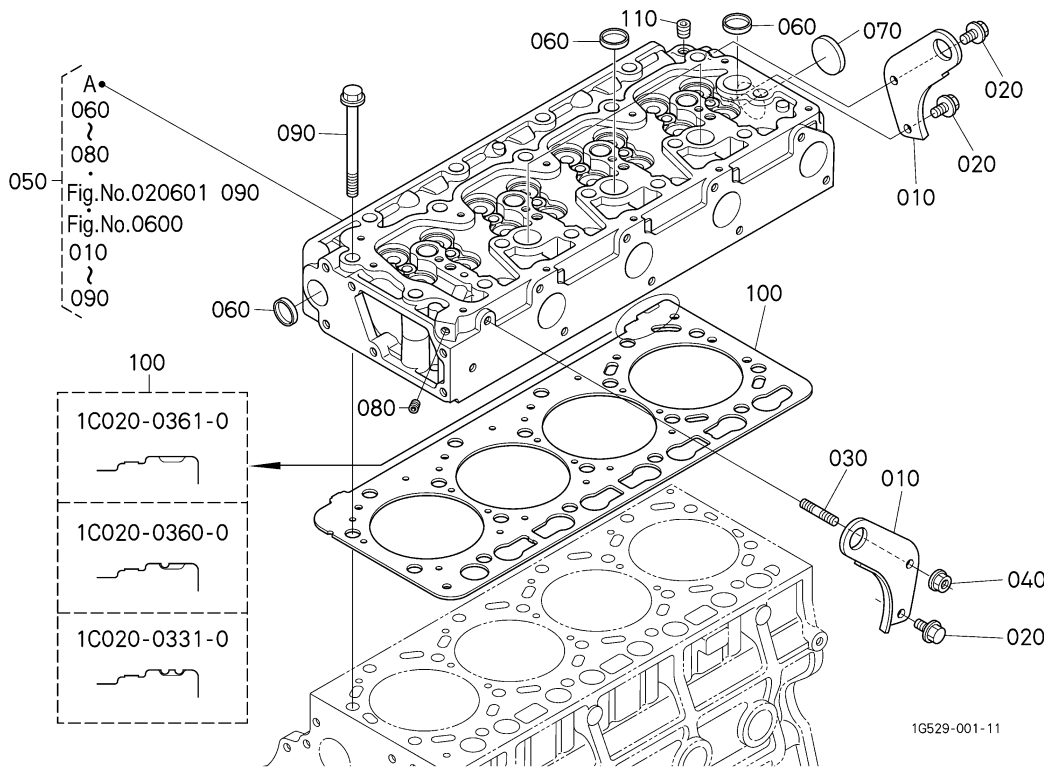

A:V3300DI-E2B-SWD-1

序号 REF. No.	零件号 PART No.	零件名称	PART NAME	数量 Q' TY/S. No.		互 换 性 I.C.	备注 REMARKS
				A	B		
010	15471-0174-0	发动机挂钩	HOOK, ENGINE	2	-		
020	01754-50814	法兰螺栓	BOLT, FLANGE	3	-		
030	15221-9153-0	双头螺栓	STUD	1	-		
040	02751-50080	法兰螺母	NUT, FLANGE	1	-		
050	1C020-0302-5	汽缸盖总成	ASSY CYLINDER HEAD	1	-		#
050	1C020-0302-6	汽缸盖总成	ASSY CYLINDER HEAD	1	-	←	#
050	1C020-0302-7	汽缸盖总成	ASSY CYLINDER HEAD	1	-	←	#
060	15221-0337-0	密封盖	CAP, SEALING	5	-		
070	15221-0349-0	密封盖	CAP, SEALING	1	-		
080	15521-9602-0	塞子	PLUG	1	-		
090	1C010-0345-0	汽缸盖螺栓	BOLT, CYLINDER HEAD	18	-		
100	1C020-0331-0	汽缸盖垫片	GASKET, CYLINDER HEAD	1	-		STD/2 NOTCH
100	1C020-0360-0	汽缸盖垫片	GASKET, CYLINDER HEAD	1	-		SUITABILITY/1 NOTCH
100	1C020-0361-0	汽缸盖垫片	GASKET, CYLINDER HEAD	1	-		SUITABILITY/NOT NOTCH
110	15841-9602-0	塞子	PLUG	1	-		



0600

气门和摇臂  
VALVE AND ROCKER ARM

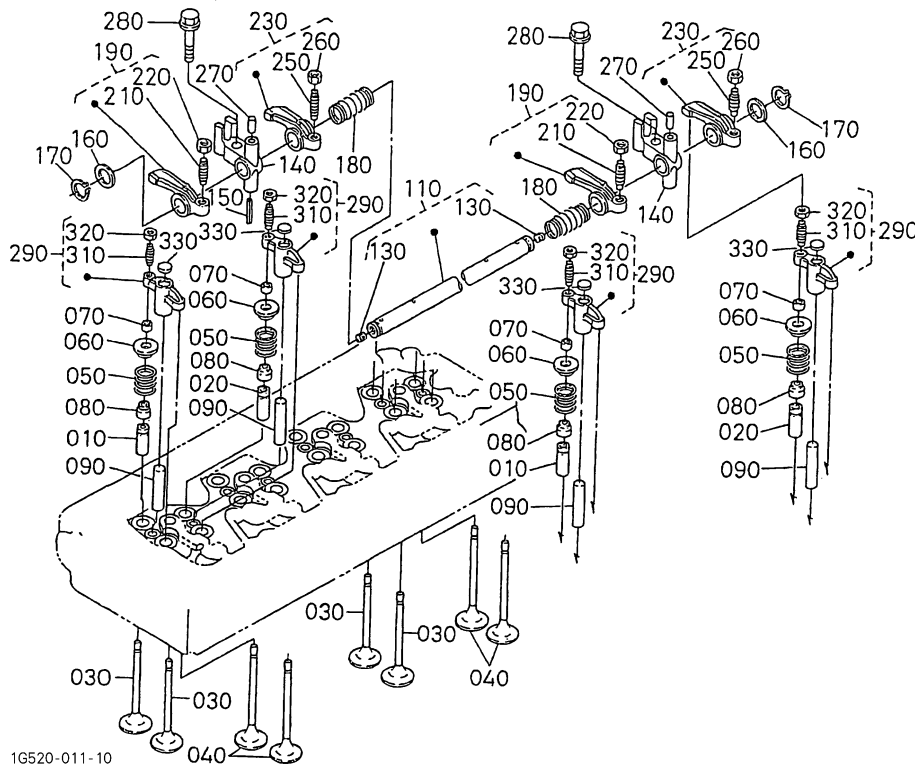

1G520-011-10

A:V3300DI-E2B-SWD-1

序号 REF. No.	零件号 PART No.	零件名称	PART NAME	数量 Q' TY/S. No.		互 换 性 I.C.	备注 REMARKS
				A	B		
010	16261-1354-0	进气门导管	GUIDE, INLET VALVE	8	-		
020	16261-1356-0	排气门导管	GUIDE, EXHAUST VALVE	8	-		
030	1C020-1311-0	进气门	VALVE, INLET	8	-	#	
030	1C020-1311-2	进气门	VALVE, INLET	8	-	← #	
040	1C020-1312-0	排气门	VALVE, EXHAUST	8	-	#	
040	1C020-1312-2	排气门	VALVE, EXHAUST	8	-	← #	
050	1C010-1324-0	气门弹簧	SPRING, VALVE	16	-		
060	16261-1333-0	气门弹簧座圈	RETAINER, SPRING	16	-		
070	15261-1336-0	气门弹簧锁片	COLLET, VALVE SPRING	16	-	SET	
080	1C010-1315-0	气门油封	SEAL, VALVE STEM	16	-		
090	1C010-1348-2	桥臂轴	SHAFT, VALVE	8	-		
100	----	空白	BLANK	-	-		
110	1C020-1405-0	摇臂轴总成	ASSY SHAFT, R-ARM	1	-		
120	----	空白	BLANK	-	-		
130	03410-50808	螺钉	SCREW, SET	2	-		
140	1C020-1435-0	摇臂轴支架	BRACKET, ROCKER ARM	4	-		
150	05411-00528	弹簧销	PIN, SPRING	1	-		
160	1C010-1443-0	垫圈	WASHER	2	-		
170	04612-00160	外圆形夹	CIR CLIP, EXTERNAL	2	-		
180	1C020-1431-0	摇臂弹簧	SPRING, ROCKER ARM	3	-		
190	1C020-1402-0	摇臂总成	ASSY ROCKER ARM, IN.	4	-		
200	----	空白	BLANK	-	-		
210	15521-1423-0	调节螺钉	SCREW, ADJUSTING	4	-		
220	15021-1424-0	螺母	NUT	4	-		
230	1C020-1415-0	摇臂总成	ASSY ROCKER ARM, EXH.	4	-		
240	----	空白	BLANK	-	-		
250	15521-1423-0	调节螺钉	SCREW, ADJUSTING	4	-		
260	15021-1424-0	螺母	NUT	4	-		
270	1C020-9451-0	圆柱销	PIN, STRAIGHT	4	-		
280	01774-51060	法兰螺栓	BOLT, FLANGE	4	-		

↔ Interchangeable; ≠ not interchangeable; ← new for old; → old for new

