

图G1/FIG. 61

起升油缸 (基本型 2-3t) / LIFT CYLINDER (NORMAL MAST M)

CPC, GPCD20, 25, 30

序号 Item No	图号 Part No	零部件名称 Description	件数 Qty	备注 Remark
A	HRD24C8402	Lift cylinder (Inc. 1~16)	2	2t, 2.5t 见选用件表 See op. parts
-	HRH26A8402	Lift cylinder (Inc. 1~16)	2	3t 见选用件表 See op. parts
01	HRD20A8508 D20B8-42327	Seal	2	2t, 2.5t
-	HRD20A8508 D28B8-42441	Seal	2	3t
02	HRD20B8406 D20B8-42331	Packing	2	2t, 2.5t
-	HRD20B8406 D28B8-42611	Packing	2	3t
03	D20B8-42391	Bushing	2	2t, 2.5t
-	D28B8-42461	Bushing	2	3t
04	Z6053-05302	O-ring	2	GB3452.1-92 2t, 2.5t
-	Z6003-06803	O-ring	2	GB1235-76 3t
05	D20B8-42341	Plug	4	
06	B1830-08008	Screw	4	GB80-85
07	H22A8-42001	Cap	2	2t, 2.5t
-	H26A8-42001	Cap	2	3t
08	H22A8-42011	sleeve	2	2t, 2.5t
-	H26A8-42011	sleeve	2	3t
09	HRH22A8403	Cylinder	2	2t, 2.5t 见选用件表 See op. parts
-	HRH26A8403	Cylinder	2	3t 见选用件表 See op. parts
10	HRD24C8403	Rod	2	2t, 2.5t 见选用件表 See op. parts
-	HRD28B8405	Rod	2	3t 见选用件表 See op. parts
11	HRD20A8405 D20A8-42451	Spacer	见表	2t, 2.5t
-	HRD20A8405 D28A8-43131	Spacer	见表	3t
12	D20B8-42371	Piston	2	2t, 2.5t
-	D28B8-42411	Piston	2	3t
13	D20B8-42381	snap ring	2	钢丝挡圈
14	HRD20A8409 D20A8-42531	Wearing	2	2t, 2.5t
-	HRD20A8409 D28A8-43171	Wearing	2	3t
15	HRD20A8509 D20A8-42541	Snap ring	2	2t, 2.5t
-	HRD20A8509 D28A8-43181	Snap ring	2	3t
16	HRD20A8505 D20A8-42551	U-ring	2	2t, 2.5t

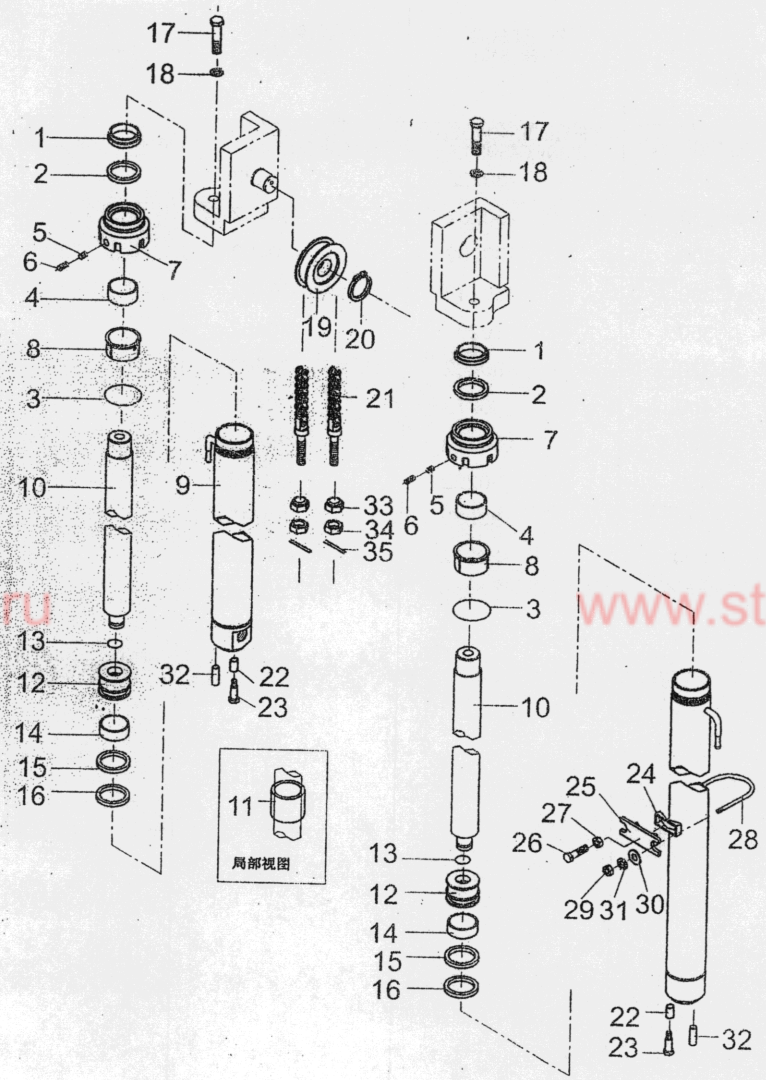

序号 Item No	图号 Part No	零部件名称 Description	件数 Q'ty	备注 Remark
-	HRD20A8405 D28A8-43191	U-ring U形密封圈	2	3t
17	B0530-16040	Bolt 螺栓M16x1.5x40	2	GB5786-86
18	B5050-00016	Washer 垫圈16	2	GB93-87
19	23659-44842	Sheave 链轮	2	
20	B6150-00040	Snap ring 弹性挡圈40	2	GB894-1-86
21	HRLH1234021	Chain (Inc.33~35) 链条总成	2	2t,2.5t 见选用件表 See op.parts
-	HRLH1623011	Chain (Inc.33~35) 链条总成	2	3t 见选用件表 See op.parts
22	HRD20B8407 D20B8-42031	Sleeve 隔套	2	
23	B0530-12025	Bolt 螺栓M12x1.25x25	2	GB5786-86
24	D20B8-42051	Spacer 调整块	2	
25	D20B8-42041	Support 油缸支撑块	2	
26	B0530-12050	Bolt 螺栓M12x1.25x50	2	GB5786-86
27	B4223-00012	Nut 螺母M12x1.25	2	GB6171-86
28	HRD208408 D20B8-42061	U-bolt U型螺栓	2	
29	B4413-00010	Nut 螺母M12x1.25	4	GB6173-86
30	B5310-00010	Washer 垫圈10	4	GB97.1-85
31	B5050-00010	Washer 弹簧垫圈10	4	GB93-87
32	B3130-10026	Pin 销B10x26	2	GB119-86
33	22198-40192G	Nut 螺母	4	
34	B4230-00018	Nut 螺母M18x1.5	4	GB6171-86
35	B3010-03030	Pin 开口销3x30	4	GB91-86

CPC,CPGD20,25,30

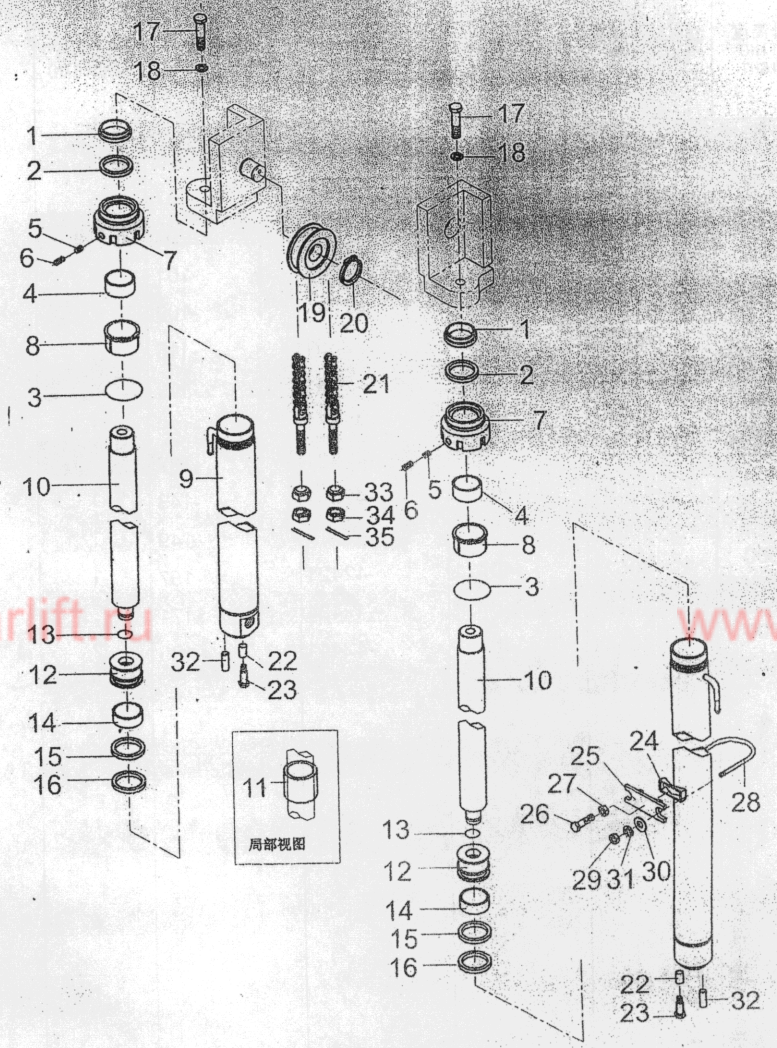

起升油缸选用件 OPTION TABLE FOR LIFT CYLINDER

起升高度 IFTING HEIGHT	起升油缸总成 LIFT CYL	缸体 LYL. BODY	活塞杆 RID. PISTON	链条总成 CHAIN ASS'Y	调整套(个) SPACER (N)
M200	D24C8 -40411	H22A8 -40611	D24C8 -42311	HRLH1234021 -75	
250	-40421	-40621	-42321	-87	
270	-40431	-40631	-42331	-93	
标准 (STD) 300	-40401	-40601	-42301	-101	
330	-40441	-40641	-42341	-109	
350	-40451	-40651	-42351	-115	
370	-40461	-40661	-42361	-119	
400	-40471	-40671	-42371	-129	1
425	-40481	-40681	-42381	-137	1
450	-40491	-40691	-42391	-143	1
475	-40511	-40711	-42411	-149	1
500	-40521	-40721	-42421	-157	1
550	-40531	-40731	-42431	-171	2
600	-40541	-40741	-42441	-185	2

CPC,CPCD20,25



图61/FIG. 61

起升油缸 (基本型 2-3t) / LIFT CYLINDER (NORMAL MAST M)

起升油缸选用件 OPTION TABLE FOR LIFT CYLINDER

起升高度 IFTING HEIGHT	起升油缸总成 LIFT CYL	缸体 LYL. BODY	活塞杆 RID, PISTON	链条总成 CHAIN ASS'Y	调整套(个) SPACER(N)
M200	H26A8	H26A8	D28B8	HRLH1623011	
250	-40411	-40611	-42211	-57	
270	-40421	-40621	-42231	-67	
标准 (STD)	-40431	-40631	-42241	-71	
300	-40401	-40601	-42201	-77	
330	-40441	-40641	-42271	-83	
350	-40451	-40651	-42281	-87	
370	-40461	-40661	-42311	-91	
380	-40551	-40751	-42991	-93	
400	-40471	-40671	-42331	-99	1
425	-40481	-40681	-42341	-103	1
450	-40491	-40691	-42351	-109	1
475	-40511	-40711	-42361	-113	1
500	-40521	-40721	-42371	-119	1
550	-40531	-40731	-42381	-131	2
600	-40541	-40741	-42391	-151	2

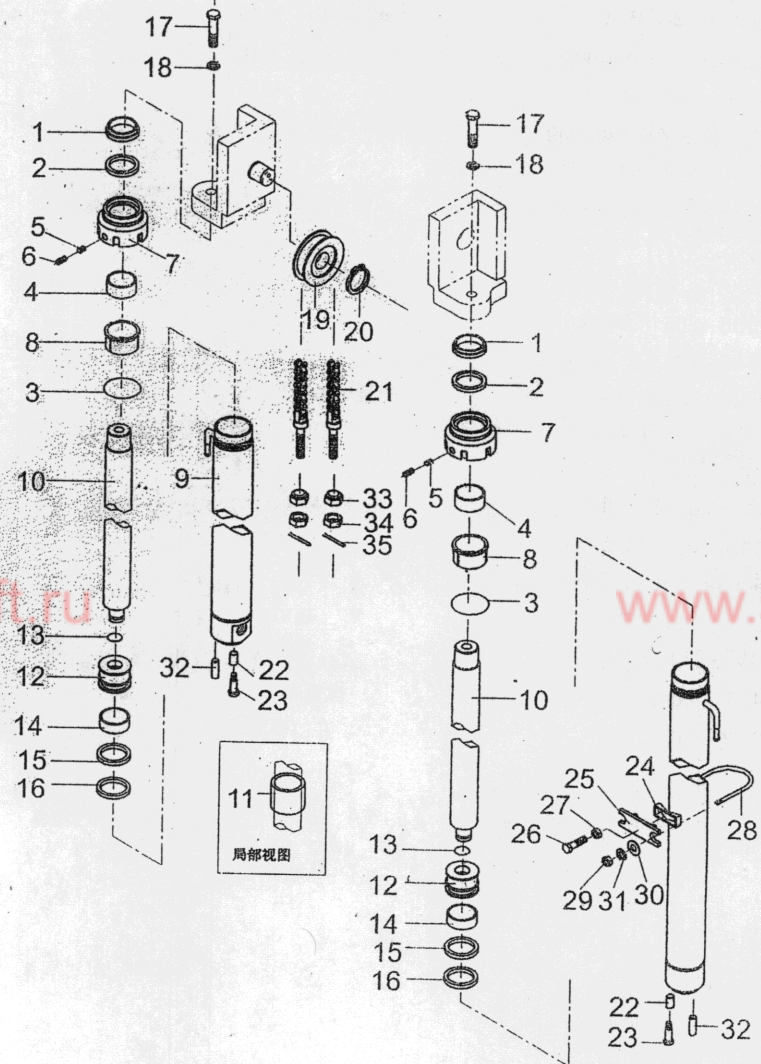
CPC, CPCD30

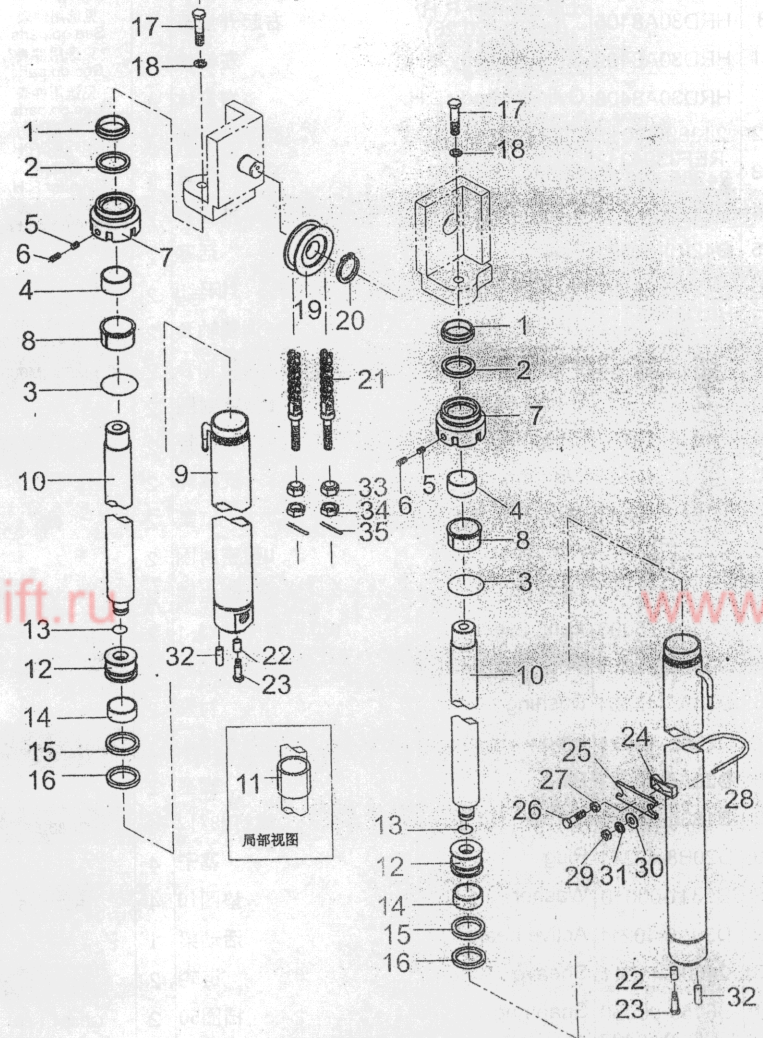

序号 Item No	图号 Part No	零部件名称 Description	件数 Q'ty	备注 Remark
A	HRD30A8406	Lift cylinder L.H. (Inc.01~20,26)	1	左起升油缸 见选用件表 See op.parts
B	HRD30A8405	Lift cylinder R.H. (Inc.01~20,26)	1	右起升油缸 见选用件表 See op.parts
01	HRD30A8409	Cylinder body L.H.	1	左缸体 见选用件表 See op.parts
-	HRD30A8408	Cylinder body R.H.	1	右缸体 见选用件表 See op.parts
02	24389-46011	Spool	1	滑阀 右缸用 Cylinder R.H.
03	REF339431 24389-46021	Spring	1	弹簧 右缸用 Cylinder R.H.
04	HRD30A8411	Piston rod	2	柱塞杆 见选用件表 See op.parts
05	D42K0-52551	Piston	2	活塞
06	D42K0-52541	Steel thread	2	钢丝B
07	HRD30A8413 D30A8-42371	Sleeve, adjusted	2	调整轴套 用于M400,M425, M450,M470,M500
08	HRD30A8413 D30A8-42391 REF340214 22439-43711	Sleeve, adjusted U-ring Seal	2	调整轴套 U型密封圈
09	24238-42031	Ring, backup	2	挡片
10	REF341311 24248-52251	Wearing	2	支承环
11	D30A8-42341	Cap	2	缸盖
12	REF340858 24329-45591	Ring seal	2	U型密封圈
13	ME-350A	Dust ring	2	防尘圈
14	Z6004-75003	O-ring seal	2	O型密封圈75X3.1 GB1235-76
15	D30A8-42361	Bushing	2	钢背轴承5040 GS-1
16	D30A8-42351	Bushing	2	衬套
17	D20A8-42421	Elbow	2	管接头
18	D20A8-42511	Plug	2	螺塞
19	B1830-08012	Screw	4	螺钉M8X12 GB80-85
20	D20B8-42341	Plug	4	塞子
21	B5311-00010	Washer	4	垫圈10 GB97.1-85
22	D30A8-40211	Active beam	1	活动梁
23	24609-41241	Sheave	2	链轮
24	B6150-00050	Snap ring	2	挡圈50 GB894.1-86
25	HRD20B8407 D20B8-42031	Spacer	2	隔套
26	23679-40050G	Pin	2	销

CPC,CPCD35



图62/FIG. 62

起升油缸 (基本型3.5t) / LIFT CYLINDER (NORMAL MAST M)

CPC/GPCD35

序号 Item No	图号 Part No	零部件名称 Description	件数 Q'ty	备注 Remark
27	B5050-00010	Washer, lock	垫圈10	4 GB93-87
28	B0530-20055	Bolt	螺栓M20X1.5X55	2 GB5786-86
29	B0430-12025	Bolt	螺栓M12X1.25X25	2 GB5786-86
30	B5050-00020	Washer, lock	垫圈20	2 GB93-87
31	HRLH1634011	Chain ass'y(Inc.32-34)	链条总成	2 见选用件表 See opt. parts
32	23818-30271	Nut	球形螺母	4
33	B4230-00022	Nut	螺母M22X1.5	4 GB6171-86
34	B3010-02540	Pin	销2.5X40	4 GB91-86
35	D42K0-62111	Support	油缸支承块	2
36	D42K0-62431	Rubber	调整块	2
37	D30A8-42111	U-bolt	U型螺栓	2
38	B0520-12040	Bolt	螺栓M12X1.25X40	2 GB5786-86
39	B4218-00012	Nut	螺母M12X1.25	4 GB6171-86
40	B4218-00010	Nut	螺母M10X1.25	2 GB6171-86

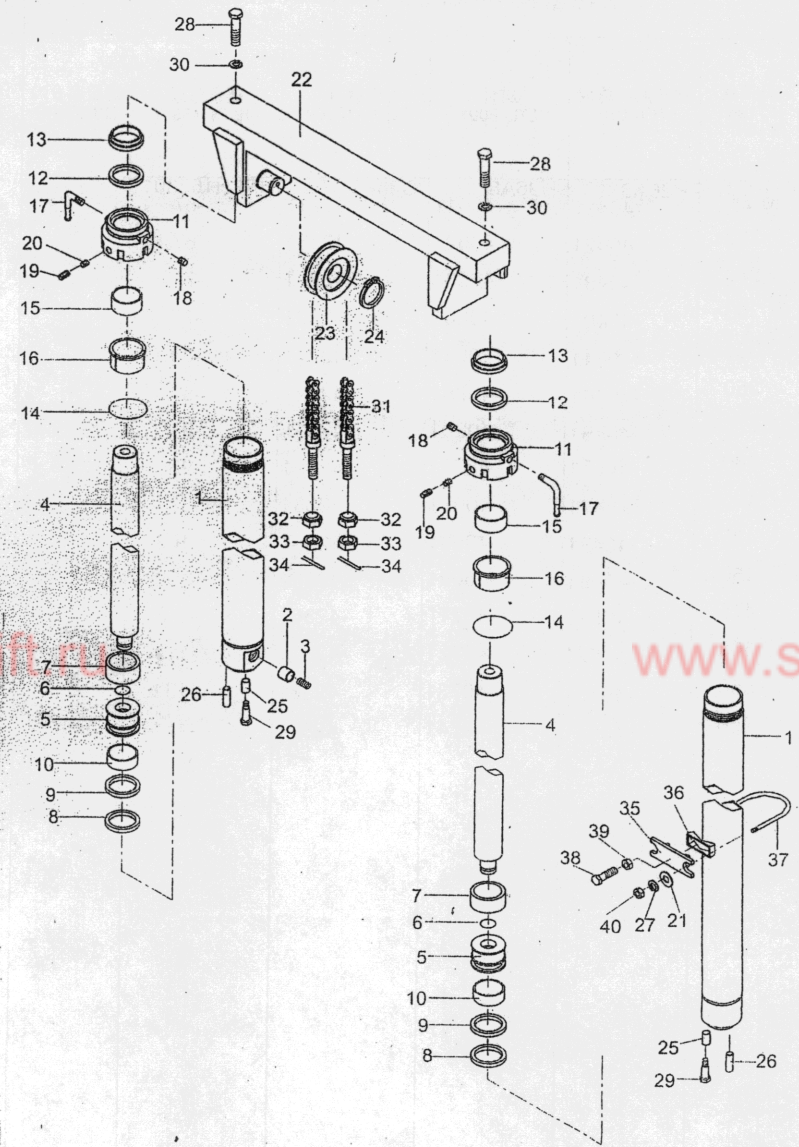
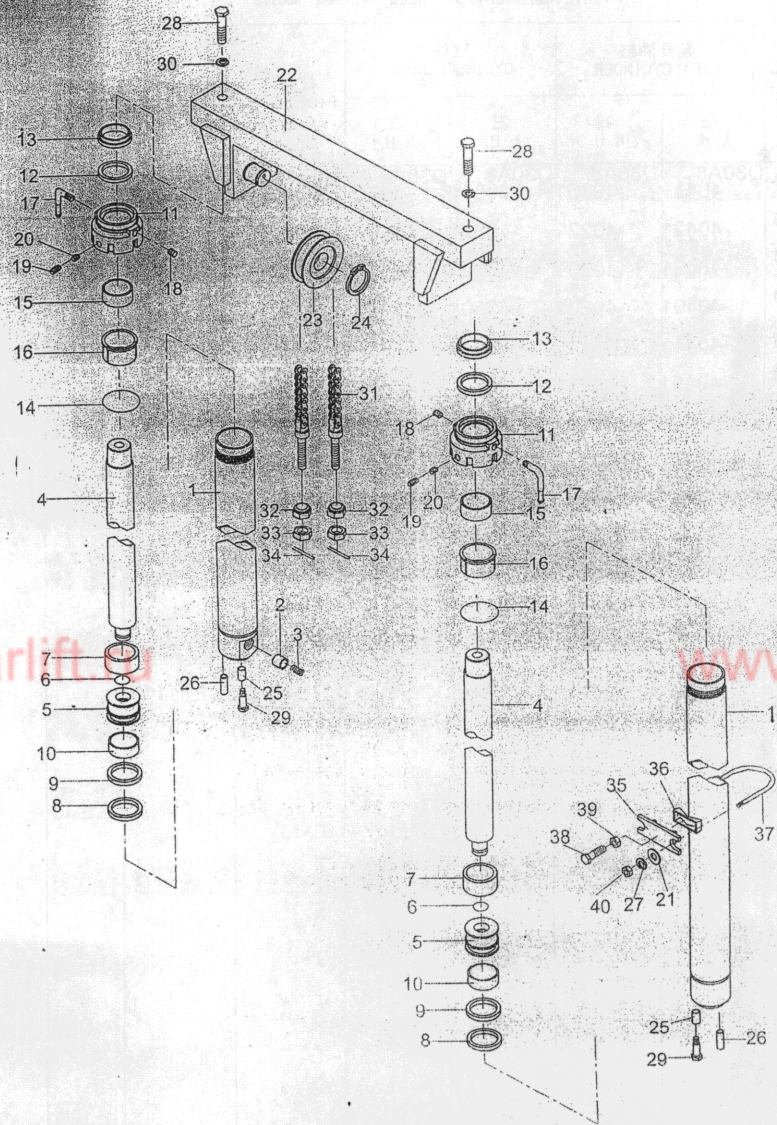

3.5t起升油缸选用件 (基本型)
LIFT CYLINDER OPTION TABLE (NORMAL MAST)

起升高度 LIFTING HEIGHT	起升油缸 LIFT CYLINDER		缸体 CYLINDER BODY		柱塞杆 PISTON ROD	链条总成 CHAIN ASS'Y	备注 REMARKS
	左 L.H.	右 R.H.	左 L.H.	右 R.H.			
M200	D30A8 -40411	D30A8 -40351	D30A8 -40811	D30A8 -40611	D30A8 -42011	HRLH1634011 -59	
250	-40421	-40221	-40821	-40621	-42021	-69	
270	-40431	-40231	-40831	-40631	-42031	-73	
300	-40401	-40201	-40801	-40601	-42001	-79	标准 (STD)
330	-40441	-40241	-40841	-40641	-42041	-85	
350	-40451	-40251	-40851	-40651	-42051	-89	
370	-40461	-40261	-40861	-40661	-42061	-93	
400	-40471	-40271	-40871	-40671	-42071	-99	
425	-40481	-40281	-40881	-40681	-42081	-105	
450	-40491	-40291	-40891	-40691	-42091	-109	
475	-40511	-40311	-40911	-40711	-42101	-115	
500	-40521	-40321	-40921	-40721	-42141	-119	
550	-40531	-40331	-40931	-40731	-42121	-131	
600	-40541	-40341	-40941	-40741	-42131	-141	

CPC, CPCD35



图63/FIG. 63

前起升油缸 (二级全自由 2-3t) / FRONT LIFT CYLINDER (FULL FREE 2-STAGE MAST ZM)

CPC, CPCD20, 25, 30

序号 Item No	图号 Part No	零部件名称 Description	件数 Qty	备注 Remark
A	REF103316G	Lift cylinder (front) (Inc.01~13, 18, 22~24)	前升降缸 1	2t, 2.5t 见选用件表 See op. parts
-	REF480010	Lift cylinder (front) (Inc.01~13, 18, 22, 23)	前升降缸 1	3t 见选用件表 See op. parts
01	23650-82402	Cap, lift cylinder	前缸盖 1	2t, 2.5t
-	64460-48201a	Cap, lift cylinder	前缸盖 1	3t
02	REF339093	Dust ring	防尘圈75 1	2t, 2.5t
-	23650-82111	Dust ring	防尘圈85 1	3t
03	REF339093	Dust ring	防尘圈85 1	3t
-	24450-82231	Yx-ring seal	Yx密封圈d75 1	2t, 2.5t
-	REF340213	Yx-ring seal	Yx密封圈d85 1	3t
-	23650-82121	Yx-ring seal	Yx密封圈d85 1	3t
-	24450-82241	Yx-ring seal	Yx密封圈d85 1	3t
04	23650-82131	Snap ring	挡圈 1	2t, 2.5t
-	25908-42471	Snap ring	挡圈 (一) 1	3t
05	Z6004-10003	O-ring seal	O型密封圈100X3 1	GB1235-76 2t, 2.5t
-	64460-00002G	O-ring seal	O型密封圈 1	3t
06	23650-82141	Snap ring	挡圈 1	2t, 2.5t
-	REF340216	Snap ring	挡圈 (二) 1	3t
-	24450-82281	Snap ring	挡圈 (二) 1	3t
07	22518-40151	Plug	螺塞 2	
08	22438-42641	Wearing	支承环 1	2t, 2.5t
-	REF340369	Wearing	支承环 1	3t
-	23878-52101	Wearing	支承环 1	3t
09	B1830-06010	Screw	螺钉M6X10 2	GB80-85 2t, 2.5t
-	B1830-06008	Screw	螺钉M6X8 2	GB80-85 3t
10	90662-63401G	Plug	塞子 2	
11	REF341084	Seal ring	密封环90X82.4X4.5 1	2t, 2.5t
-	53658-42011	Seal ring	密封环100X92.4X4.3 1	3t
-	REF341084	Seal ring	密封环100X92.4X4.3 1	3t
-	54458-42011	Seal ring	密封环100X92.4X4.3 1	3t
12	REF209336	Piston rod ass'y	柱塞杆总成 1	2t, 2.5t 见选用件表 See op. parts
-	REF481010	Piston rod ass'y	柱塞体 1	3t 见选用件表 See op. parts
13	REF207154G	Cylinder body(front)	前缸体 1	2t, 2.5t 见选用件表 See op. parts
-	REF482010	Cylinder body(front)	前缸体 1	3t 见选用件表 See op. parts
14	B0230-16080	Bolt	螺栓M16X80 1	GB5782-86
15	B5050-00016	Washer, lock	垫圈16 1	GB93-87
16	23650-82501	Sheave seat	链轮座 1	
17	20028-00280	Stopper, chain	护链板 1	

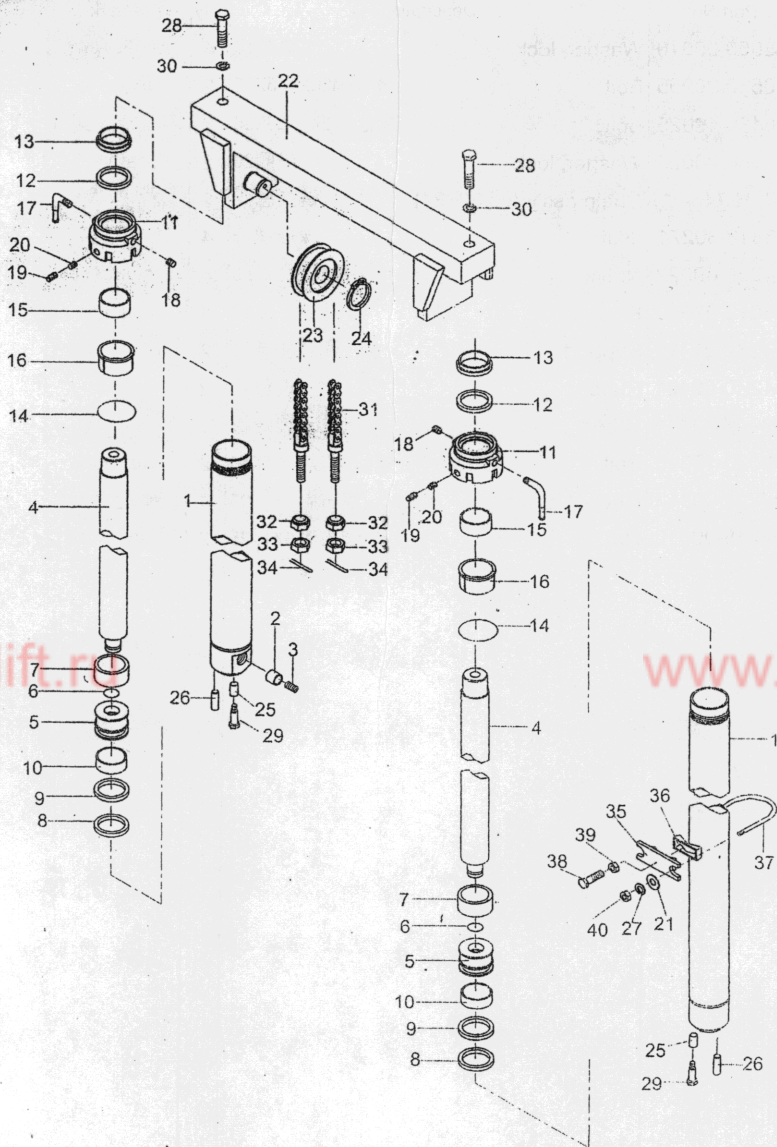

图63/FIG. 63

前起升油缸 (二级全自由 2-3t)

FRONT LIFT CYLINDER (FULL-FREE 2-STAGE MAST ZM)

序号 Item No	图号 Part No	零部件名称 Description	件数 Q'ty	备注 Remark
18	GS-1	Bushing 钢背轴承7530	1	2t, 2.5t
-	Z2111-08540	Bushing 钢背轴承8540	1	3t
19	B0530-10020	Bolt 螺栓M10X1.25X20	2	GB5786-86
20	B0530-10030	Bolt 螺栓M12X1.25X30	1	
21	D20L0-54011	Support 固定卡	1	2t, 2.5t
-	D20Q0-72101	Support 固定卡	1	3t
22	23650-82371A	Spool 阀芯	1	2t, 2.5t
-	20030-48341	Spool 阀芯	1	3t
23	REF339431 24230-52701	Spring 弹簧	1	2t, 2.5t
-	24389-46021	Spring 弹簧	1	3t
24	24230-82071	Seal, spring 弹簧座	1	2t, 2.5t
25	D10P0-22001	Spacer 隔套	1	
26	B5050-00010	Washer, lock 垫圈10	2	GB93-87
27	HRLH1234021	Chain ass'y (Inc.30-32) 链条总成	2	2t, 2.5t 见选用件表 See op parts
-	HRLH1623011	Chain ass'y (Inc.30-32) 链条总成	2	3t 见选用件表 See op parts
28	23659-44842	Sheave 链轮	2	
29	B6150-00040	Snap ring 挡圈40	2	GB894-1-86
30	22198-40192G	Nut 螺母	4	
31	B4230-00018	Nut 螺母M18x1.5	4	GB6171-86
32	B3010-03030	Pin 开口销3x30	4	GB91-86

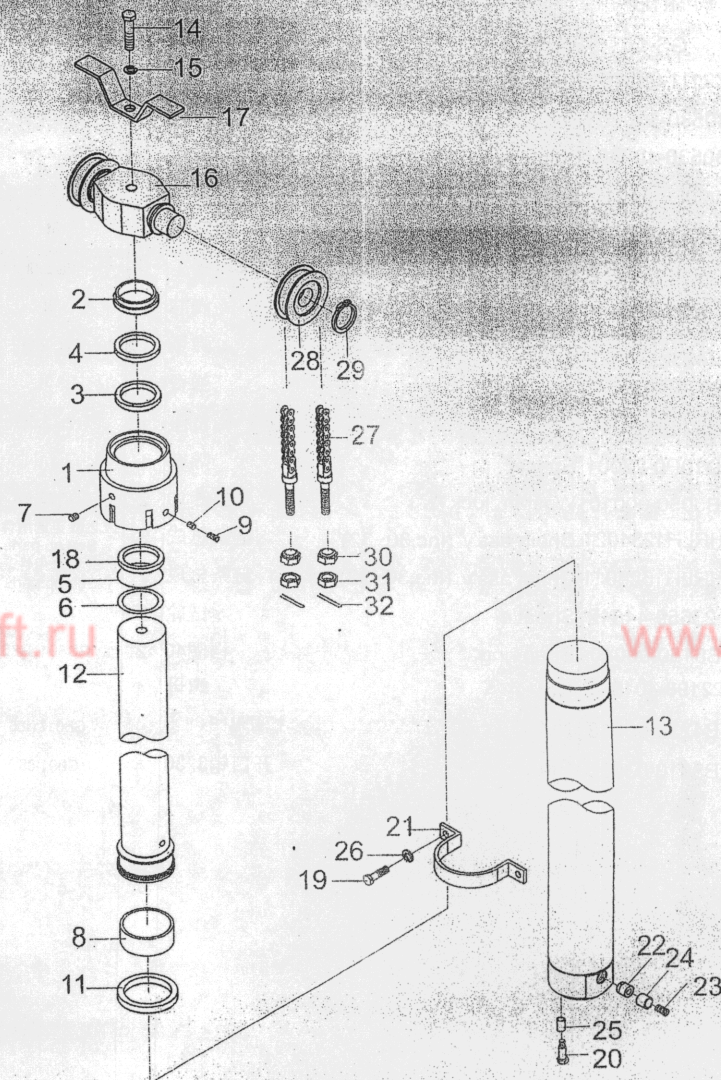
CPC, CPCD20, 25, 30



图63/FIG. 63

前起升油缸 (二级全自由 2-3t) / FRONT LIFT CYLINDER (FULL FREE 2-STAGE MAST ZM)

2.2.5t 前起升缸选用件 (二级全自由门架)
 OPTIONAL PARTS 2/2.5 TON FRONT LIFT CYLINDER (FULL FREE 2-STAGE MAST)

CPC,GPCD20,25

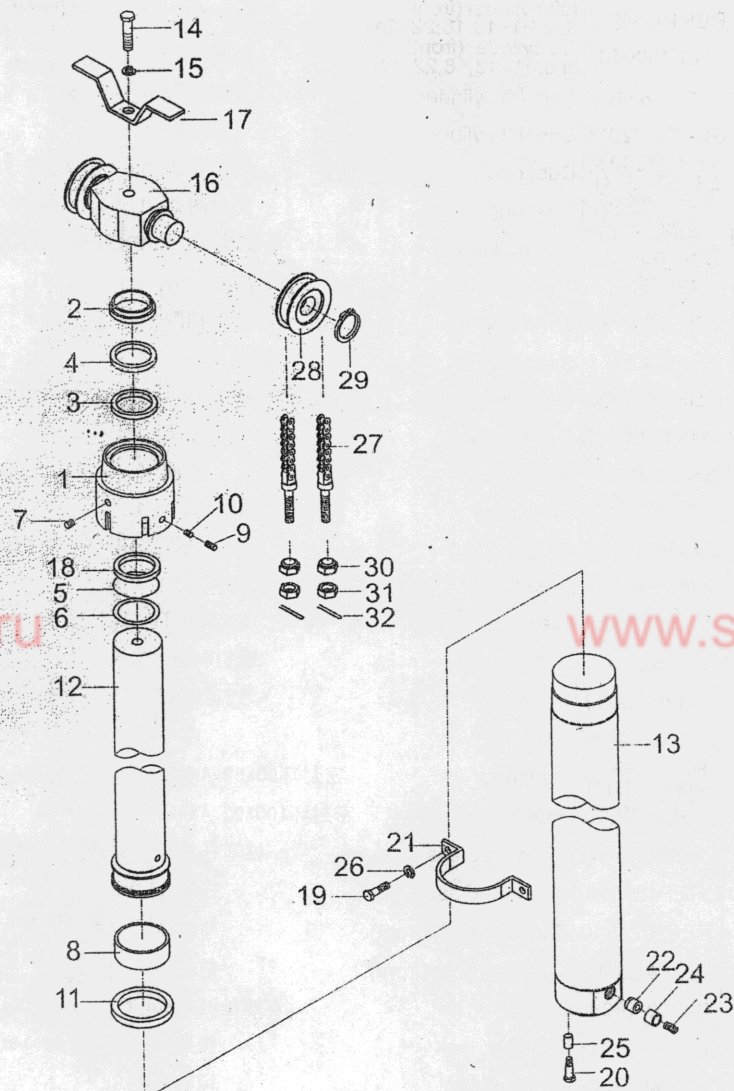
起升高度 LIFTING HEIGHT	前升降缸 LIFT CYLINDER	柱塞杆总成 POSTION ROD ASS 'Y	前缸体 CYLINDER BODY	链条总成 CHAIN ASS'Y	备注 REMARKS
ZM	22679	23650	23650	HRLH1234021	
200	-45591	-50411	-50212G	-59	
225	-45671	-50421	-50222G	-67	
250	-45671	-50431	-50232G	-67	
270	-45711	-50441	-50242G	-71	
275	-45691	-50451	-50252G	-69	
300	-45751	-50401	-50202G	-75	标准 (STD)
325	-45831	-50461	-50262G	-83	
330	-45831	-50471	-50272G	-83	
350	-45891	-50481	-50282G	-89	
366	-45931	-50491	-50292G	-93	
370	-45951	-50501	-50302G	-95	
375	-45951	-50511	-50312G	-95	
400	-46051	-50521	-50322G	-105	
425	-46111	-50531	-50332G	-111	
450	-46171	-50541	-50342G	-117	
475	-46251	-50551	-50352G	-125	
500	-46311	-50561	-50362G	-131	
550	-46471	-50571	-50372G	-145	
600	-46591	-50581	-50382G	-159	

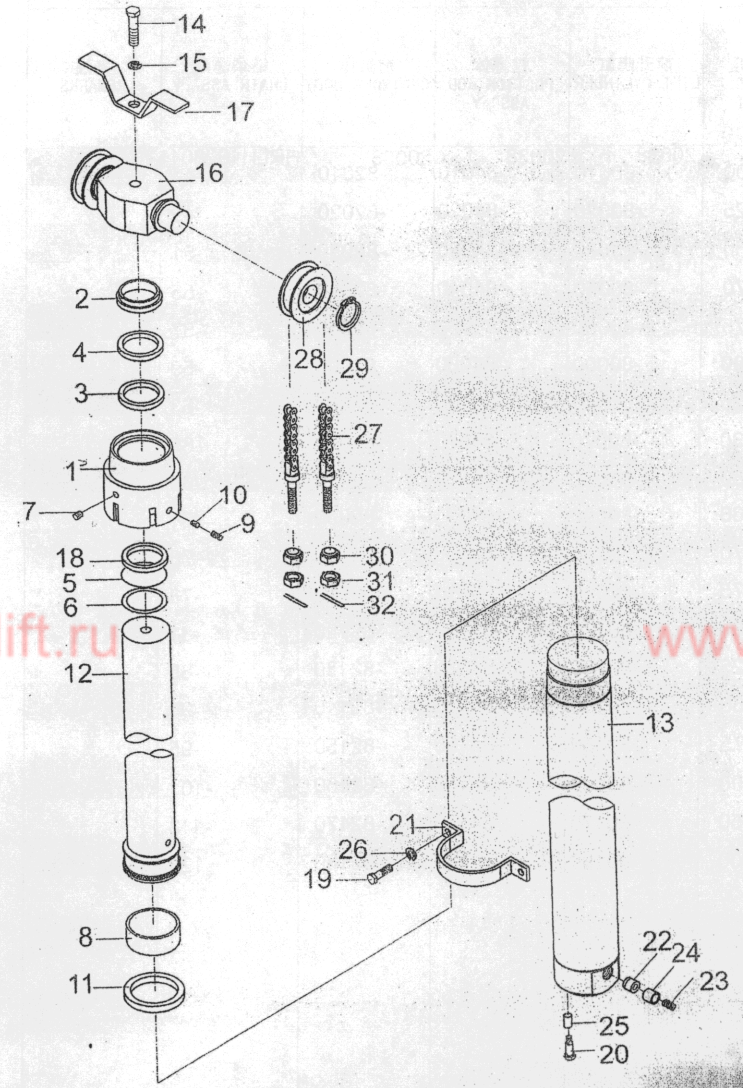

3t前起升缸选用件 (二级全自由门架)
 OPTIONAL PARTS 3 TON FRONT LIFT CYLINDER (FULL FREE 2-STAGE MAST)

起升高度 IFTING HEIGHT	前升降缸 LIFT CYLINDER	柱塞体 POSTION ROD ASS' Y	前缸体 CYLINDER BODY	链条总成 CHAIN ASS' Y	备注 REMARKS
ZM 200	20038-80010	20038-84010	20038-82010	HRLH1623011-47	
225	-80020	-84020	-82020	-49	
250	-80030	-84030	-82030	-51	
270	-80040	-84040	-82040	-55	
275	-80050	-84050	-82050	-57	
300	-80000	-84000	-82000	-59	标准 (STD)
325	-80060	-84060	-82060	-63	
330	-80070	-84070	-82070	-65	
350	-80080	-84080	-82080	-69	
366	-80090	-84090	-82090	-71	
370	-80100	-84100	-82100	-73	
375	-80110	-84110	-82110	-73	
400	-80120	-84120	-82120	-81	
425	-80130	-84130	-82130	-85	
450	-80140	-84140	-82140	-91	
475	-80150	-84150	-82150	-95	
500	-80160	-84160	-82160	-101	
550	-80170	-84170	-82170	-113	
600	-80180	-84180	-82180	-123	

CPC, CPD30



图64/FIG. 64 前起升油缸 (二级全自由 3.5t) /FRONT LIFT CYLINDER (FULL FREE 2-STAGE MAST ZM)

序号 Item No	图号 Part No	零部件名称 Description	件数 Q'ty	备注 Remark
A	HRD30K0501	Front lift cylinder (Inc.16~31) 前起升油缸	1	
01	D30K0-50211	Sheave seat 链轮座	1	
02	HRLH1634011-N	Chain ass'y (Inc.13-15) 链条总成 (包含13-15)	2	见选用件表 See Op. Parts
03	D20B8-42031	Spacer 隔套	1	
04	B0532-12035	Bolt 螺栓M12X1.25X35	1	GB5786-86
05	B0532-10020	Bolt 螺栓M10X1.25X20	2	GB5786-86
06	B5052-00010	Washer 垫圈10	2	GB93-87
07	D30K0-52031	Support 固定卡	1	
08	B6152-00040	Snap ring 挡圈40	2	GB894.1-86
09	24609-41241	Sheave 链轮	2	
10	B5052-00016	Washer 垫圈16	1	GB93-87
11	B0230-16070	Bolt 螺栓M16X70	1	GB5782-86
12	D30K0-52021	Stopper,chain 护链板	1	
13	B3010-02540	Pin 销2.5X40	2	GB91-86
14	B4230-00022	Nut 螺母M22X1.5	2	GB6171-86
15	23818-30271	Nut 球形螺母	2	
B	HRD30K0501	Front lift cylinder 前起升缸	1	见选用件表 See Op. Parts
16	HRD30K0502	Piston rod ass'y 柱塞杆总成	1	见选用件表 See Op. Parts
17	D30K0-52501	Dust ring 防尘圈ME-3 95	1	
18	D30K0-52511	Yx-ring Yx密封圈D2 95	1	
19	D30K0-52521	Snap ring 挡圈	1	
20	Q/ZB223.2	Plug 螺塞Z1/4"	1	
21	ORAR00350-N90	O-ring O型密封圈1.16.84X5.33	1	
22	D30K0-52531A	Cap, lift cylinder 前缸盖	1	
23	HRD30K0503	Front lift cylinder body 前缸体	1	见选用件表 See Op. Parts
24	D30K0-52541	Wearing 支承环	1	
25	D30K0-52551	Seal 密封环	1	
26	REF339431 24389-46021	Spring 弹簧	1	
27	D30K0-52561	Valve 滑阀	1	
28	90662-63401G	Plug 塞子	1	

CPC, CPCD35

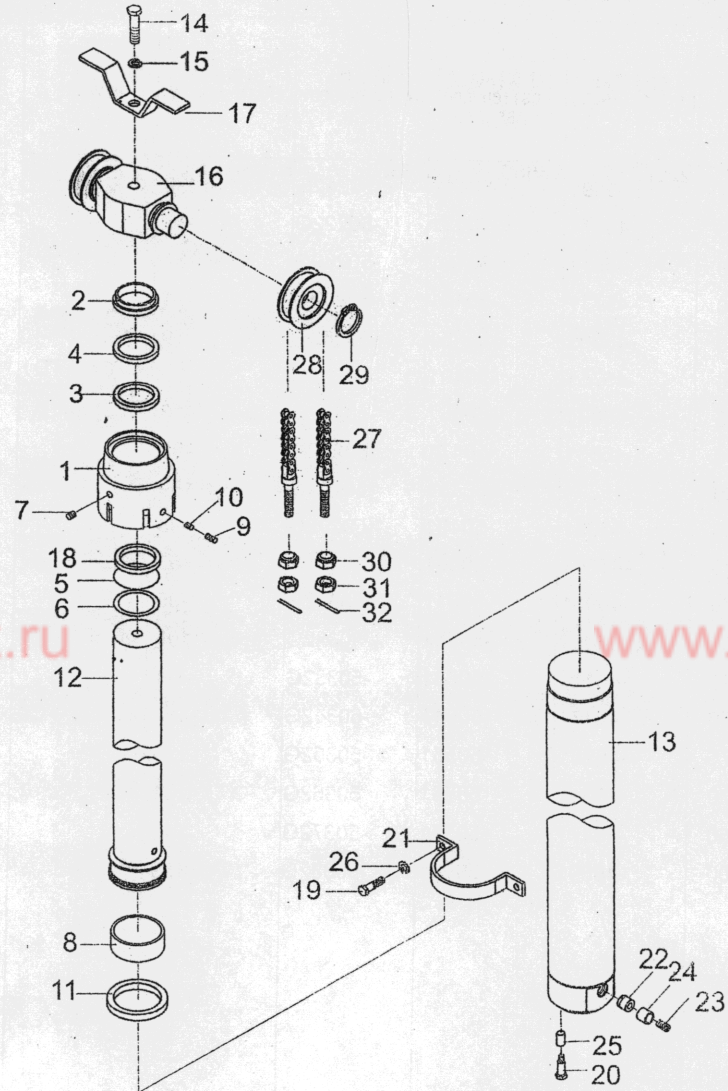
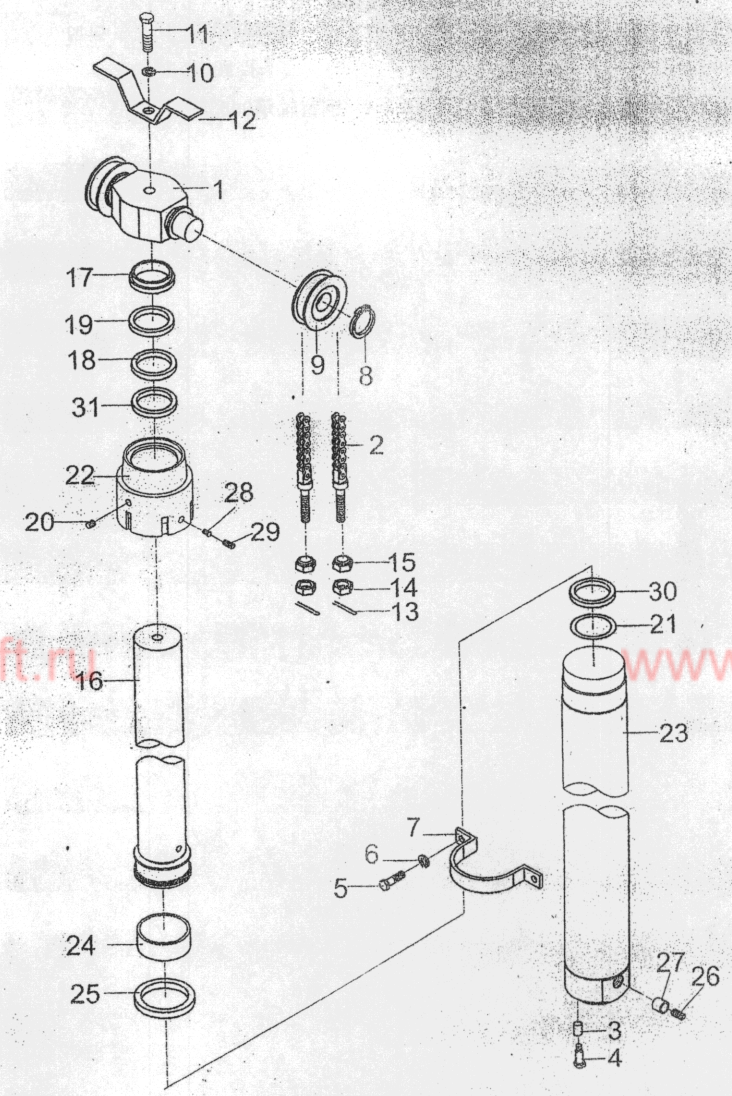

前起升油缸用件 OPTION TABLE FOR LIFT CYLINDER

GPC/PCD35

起升高度 LIFTING HEIGHT	前起升油缸 LIFT CYL.	前缸体 LYL. BODY	柱塞杆总成 RID, PISTON	链条节数 (N) CHAIN, LEAF
ZM200	HRD30K0501 D30K0-50411	HRD30K0503 D30K0-50721	HRD30K0502 D30K0-50561	HRLH1634011 -53
250	-50421	-50731	-50571	-63
270	-50431	-50741	-50581	-65
标准 (STD) 300	-50401	-50751	-50591	-69
330	-50441	-50761	-50611	-75
350	-50451	-50771	-50621	-79
370	-50461	-50781	-50631	-83
400	-50471	-50791	-50641	-89
425	-50481	-50811	-50651	-95
450	-50511	-50821	-50661	-101
475	-50521	-50831	-50671	-105
500	-50531	-50841	-50681	-111
550	-50541	-50851	-50691	-123
600	-50551	-50861	-50711	-133



图65/FIG. 65

后起升油缸 (二级全自由 2-3t) / REAR LIFT CYLINDER (FULL FREE 2-STAGE MAST ZM)

CPC,CPGD20,25,30

序号 Item No	图号 Part No	零部件名称 Description	件数 Q'ty	备注 Remark	
A	REF104794G	Lift cylinder (rear) (Inc.1~14,17,18,20,21)	后升降油缸	1	2t, 2.5t
-	REF200330	Lift cylinder (rear) (Inc.1~14,17,18,20,21)	后升降油缸	1	3t
01	23650-52831G	Cap, cylinder	缸盖	2	2t, 2.5t
-	20038-36500	Cap, cylinder	缸盖	2	3t
02	23650-52911	O-ring seal	O型密封圈	2	2t, 2.5t
-	Z6003-06003	O-ring seal	O型密封圈60 X3	1	GB1235-76 3t
03	23650-52881	Snap ring	挡圈	2	2t, 2.5t
-	20030-52881	Snap ring	挡圈	2	3t
04	REF340213	Yx-ring seal	Yx型密封圈d35	2	2t, 2.5t
-	FU0497K0	Yx-ring seal	Yx型密封圈d40	2	3t
5	23650-52861	Snap ring	挡圈	2	2t, 2.5t
-	REF340216	Snap ring	挡圈	2	3t
06	REF339093	Dust ring	防尘圈35	2	2t, 2.5t
-	REF339093	Dust ring	防尘圈40	2	3t
7	20020-10450A	Joint rod	连接杆	1	
8	Z2113-04030	Bushing	钢背轴承4030	2	GS-1
9	B1830-06010	Screw	螺钉M6X10	4	GB60-85
-	90662-63401G	Plug	塞子	4	3t
10	Z6004-02602	O-ring seal	O型密封圈26X2	4	GB1235-76
11	23650-82371	Spool	阀芯	1	
12	27978-42601	Spring	弹簧	1	
13	Q/ZB223.1	Plug	螺塞Z1/8"	4	
14	B3120-10025	Pin	销10X25	2	GB119-86 2t, 2.5t
-	B3120-10024	Pin	销10X24	2	GB119-86 3t
15	HRD20B8407 D20B8-42031	Spacer	隔套	2	
16	B0530-16035	Bolt	螺栓M16X1.5X35	2	GB5786-86
17	22580-53321G	Wearing	支承环	2	2t, 2.5t
-	REF340369 27970-53141	Wearing	支承环	2	3t
18	REF104420G	Cylinder body(L.H. &R.H.)	缸体(左右各一)	2	2t, 2.5t
-	REF200360	Cylinder body(L.H. &R.H.)	缸体(左右各一)	2	3t

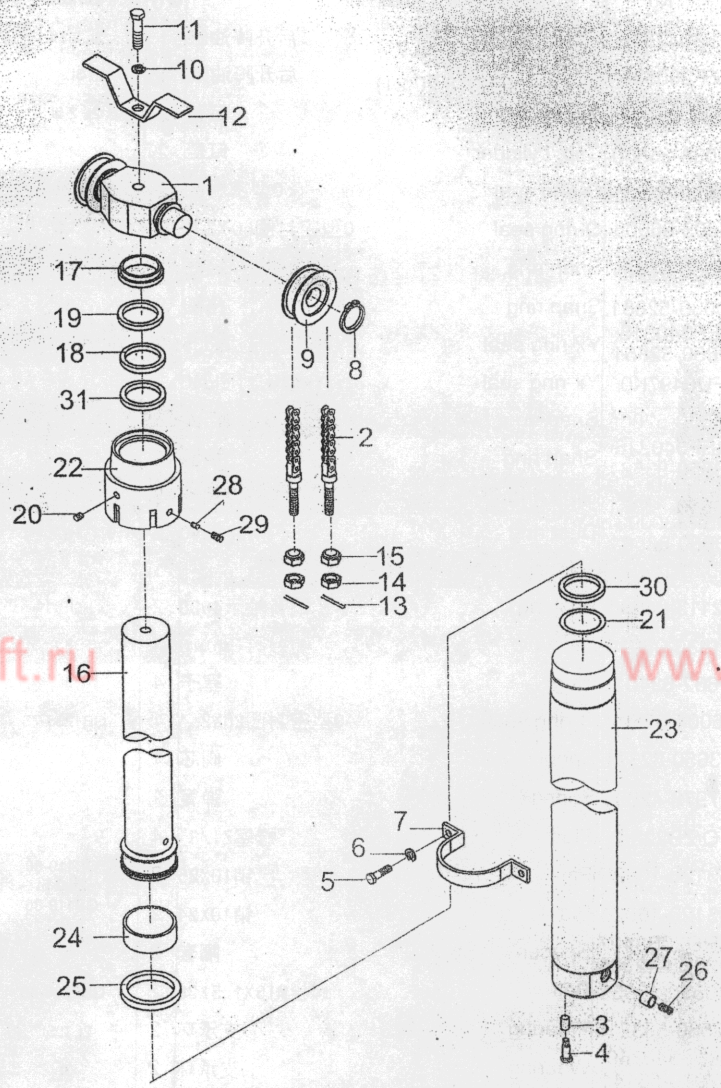
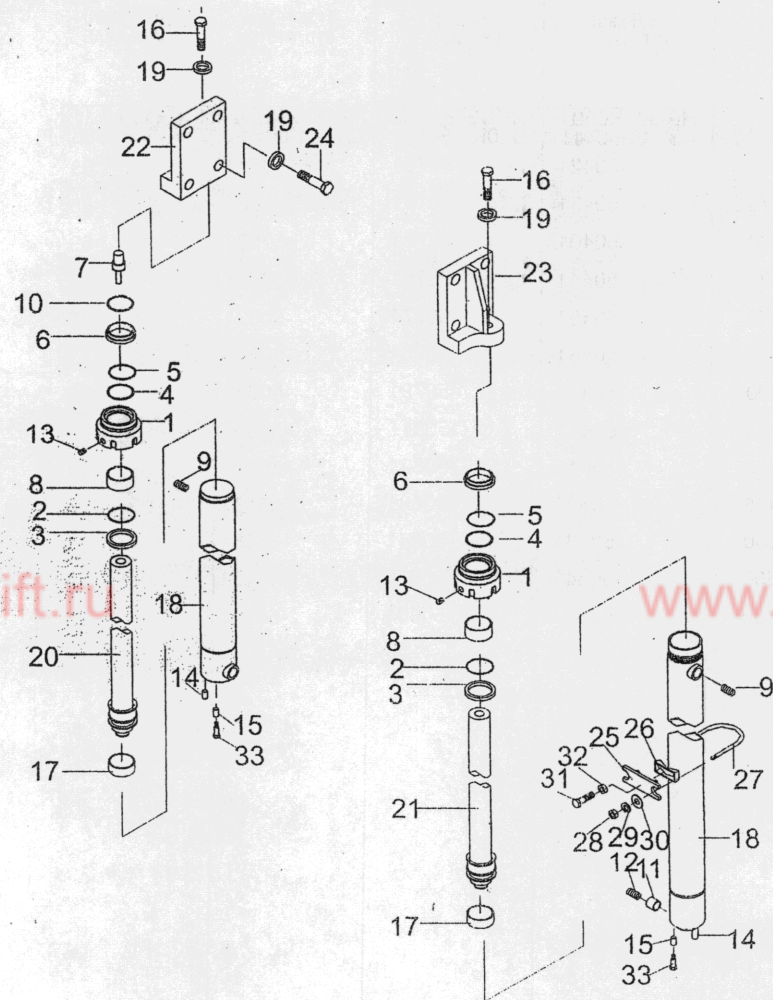

序号 Item No	图号 Part No	零部件名称 Description	件数 Q'ty	备注 Remark
19	B5050-00016	Washer, lock	10	GB93-87
20	REF207961	Piston rod ass'y ,R.H.	1	2t, 2.5t
	REF200370	Piston rod ass'y ,R.H.	1	3t
21	REF208213	Piston rod ass'y, L.H.	1	2t, 2.5t
	REF200340	Piston rod ass'y, L.H.	1	3t
22	HRD20L0503 D20L0-50301	Bracket, R.H.	1	2t, 2.5t
	HRD20L0503 D28L0-50301	Bracket, R.H.	1	3t
23	HRD20L0503 D20L0-50201	Bracket, L.H.	1	2t, 2.5t
	HRD20L0503 D28L0-50201	Bracket, L.H.	1	3t
24	B0330-16040	Bolt	8	GB5783-86
25	D20B8-42041	Support	2	
26	D20B8-42051	Rubber	2	
27	HRD20B8408 D20B8-42061	U-bolt	2	
28	B4413-00010	Nut	4	GB6173-86
29	B5050-00010	Washer, lock	4	GB93-87
30	B5310-00010	Washer	4	GB97,1-85
31	B0530-12040	Bolt	2	GB5786-86
32	B4116-00012	Nut	2	GB6170-86
33	B0530-12025	Bolt	2	GB5786-86

QPC, CPCD20, 25, 30

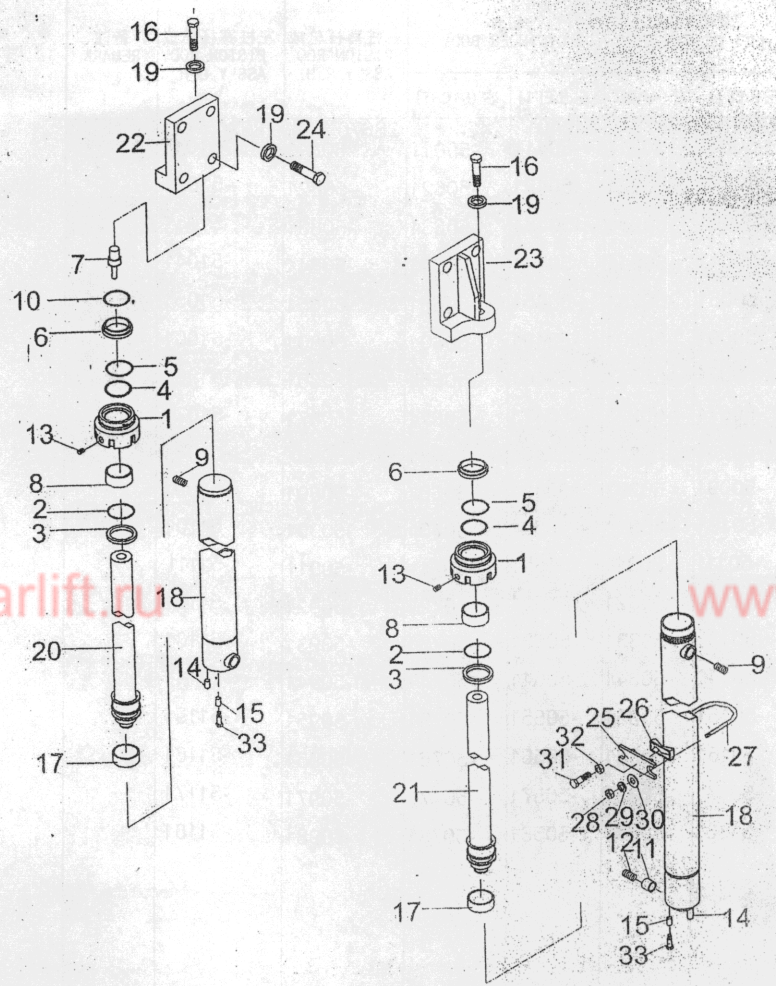

2-2.5t叉车后起升油缸选用件 (二级全自由门架)
REAR LIFT CYLINDER OPTIONAL PARTS (FULL FREE 2-STAGE MAST)

起升高度 LIFTING HEIGHT	后起升油缸 LIFT CYLINDER (REAR)		缸体 CYLINDER BODY		右柱塞杆总成 PISTON ROD ASS'Y, R. H.	左柱塞杆总成 PISTON ROD ASS'Y, L. H.	备注 REMARK
	左 (LEFT)	右 (RIGHT)	左 (LEFT)	右 (RIGHT)			
ZM	23670	23670	24240	24240	23670	23670	
200	-50011	-50211	-50411	-50611	-50811	-51011	
225	-50021	-50221	-50421	-50621	-50821	-51021	
250	-50031	-50231	-50431	-50631	-50831	-51031	
270	-50041	-50241	-50441	-50641	-50841	-51041	
275	-50051	-50251	-50451	-50651	-50851	-51051	
300	-50001	-50201	-50401	-50601	-50801	-51001	标准 (STD)
325	-50061	-50261	-50461	-50661	-50861	-51061	
330	-50071	-50271	-50471	-50671	-50871	-51071	
350	-50081	-50281	-50481	-50681	-50881	-51081	
366	-50091	-50291	-50491	-50691	-50891	-51091	
370	-50101	-50301	-50501	-50701	-50901	-51101	
375	-50111	-50311	-50511	-50711	-50911	-51111	
400	-50121	-50321	-50521	-50721	-50921	-51121	
425	-50131	-50331	-50531	-50731	-50931	-51131	
450	-50141	-50341	-50541	-50741	-50941	-51141	
475	-50151	-50351	-50551	-50751	-50951	-51151	
500	-50161	-50361	-50561	-50761	-50961	-51161	
550	-50171	-50371	-50571	-50771	-50971	-51171	
600	-50181	-50381	-50581	-50781	-50981	-51181	

CPC, CPCD20,25

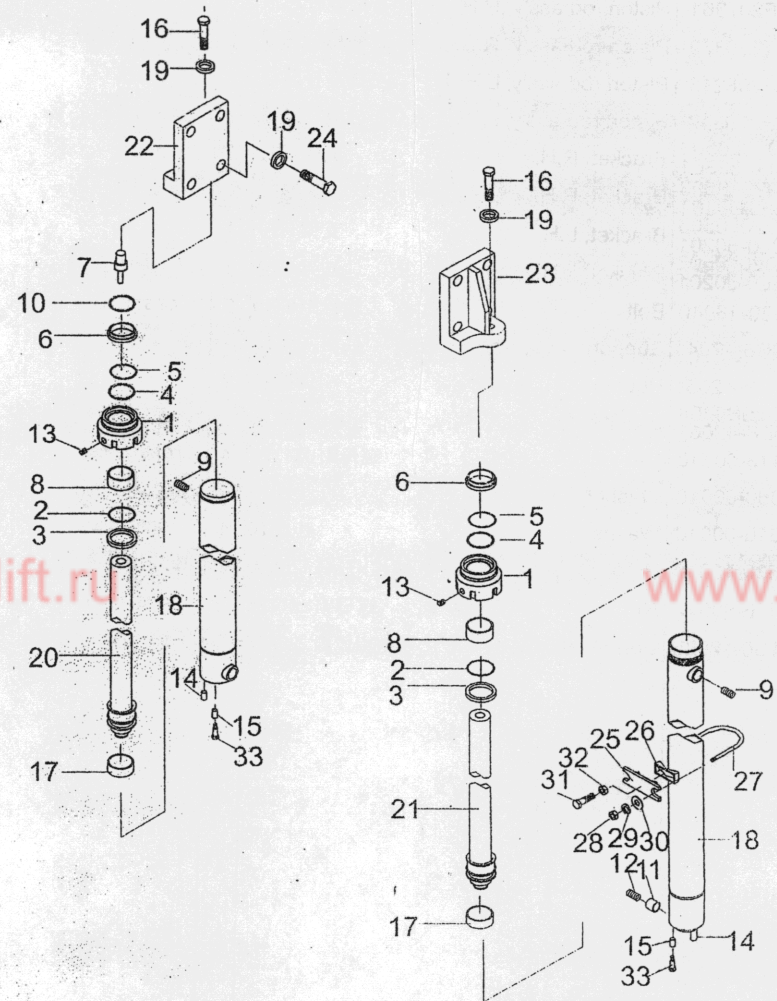

3t叉车后起升油缸选用件 (二级全自由门架)
 REAR LIFT CYLINDER OPTIONAL PARTS (FULL FREE 2-STAGE MAST)

起升高度 LIFTING HEIGHT	后起升油缸 LIFT CYLINDER (REAR)		缸体 CYLINDER BODY		右柱塞杆总成 PISTON ROD ASS'Y. R. H.	左柱塞杆总成 PISTON ROD ASS'Y. L. H.	备注 REMARK
	左(LEFT)	右(RIGHT)	左(LEFT)	右(RIGHT)			
ZM	20030	20030	20036	20036	20036	20036	
200	-50210	-50010	-31010	-41010	-17010	-26010	
225	-50220	-50020	-31020	-41020	-17020	-26020	
250	-50230	-50030	-31030	-41030	-17030	-26030	
270	-50240	-50040	-31040	-41040	-17040	-26040	
275	-50250	-50050	-31050	-41050	-17050	-26050	
300	-50200	-50000	-31000	-41000	-17000	-26000	标准 (STD)
325	-50260	-50060	-31060	-41060	-17060	-26060	
330	-50270	-50070	-31070	-41070	-17070	-26070	
350	-50280	-50080	-31080	-41080	-17080	-26080	
366	-50290	-50090	-31090	-41090	-17090	-26090	
370	-50300	-50100	-31100	-41100	-17100	-26100	
375	-50310	-50110	-31110	-41110	-17110	-26110	
400	-50320	-50120	-31120	-41120	-17120	-26120	
425	-50330	-50130	-31130	-41130	-17130	-26130	
450	-50340	-50140	-31140	-41140	-17140	-26140	
475	-50350	-50150	-31150	-41150	-17150	-26150	
500	-50360	-50160	-31160	-41160	-17160	-26160	
550	-50370	-50170	-31170	-41170	-17170	-26170	
600	-50380	-50180	-31180	-41180	-17180	-26180	

CPC, CPCD30

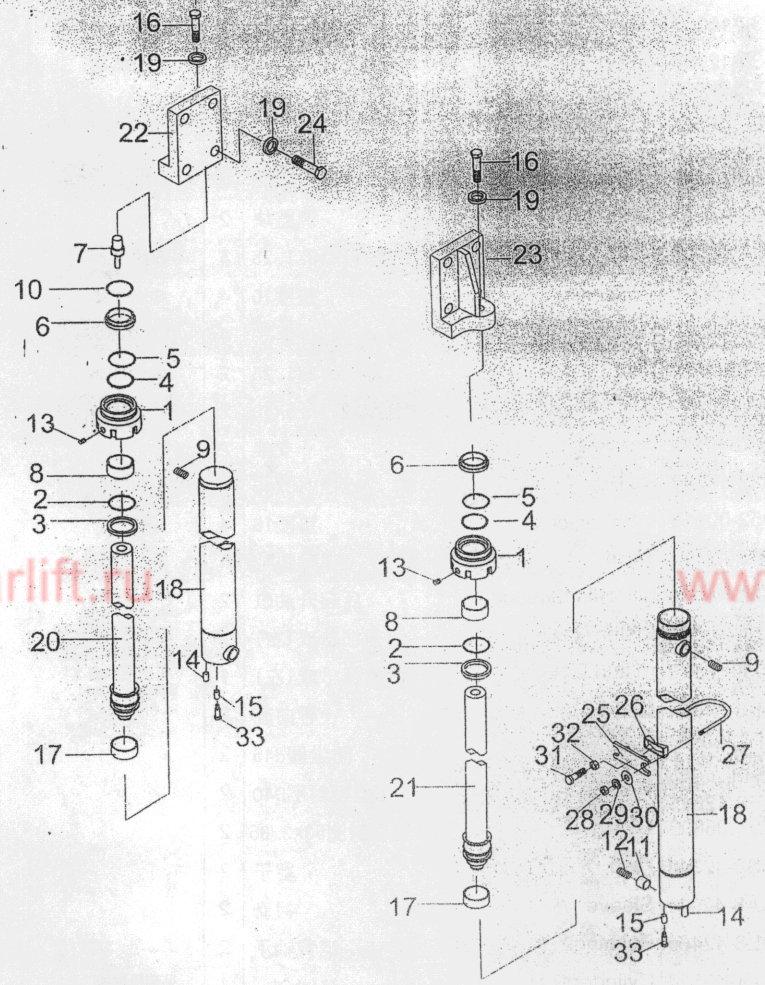

序号 Item No	图号 Part No	零部件名称 Description	件数 Q'ty	备注 Remark
A	HRD30K0510	Lift cylinder rear (Inc.17~36)	2	
01	B5052-00016	Washer,lock	2	GB93-87
02	B0332-16035	Bolt	4	GB5783-86
03	B0430-12030	Bolt	2	GB5785-86
04	HRD20B8407 D20B8-42031	Sleeve	2	
05	HRD20B8404 D28B8-42521	U-bolt	2	
06	D20B8-42041	Support	2	
07	D20B8-42051	Spacer	2	
08	B4218-00010	Nut	4	GB6171-86
09	B5311-00010	Washer	4	GB97.1-85
10	B5052-00010	Washer,lock	4	GB93-87
11	B4218-00012	Nut	2	GB6171-86
12	B0520-12040	Bolt	2	GB5786-86
13	D30K0-40291	Bracket	2	
14	B0332-18045	Bolt	4	GB5783-86
15	B5052-00018	Washer,lock	4	GB93-87
16	D30K0-42061	Shim	4	
B	HRD30K0510	Lift cylinder,back	2	见选用件表 See op. Parts
17	HRD30K0511	Piston R.H.	1	见选用件表 See op. Parts
-	HRD30K0512	Piston L.H.	1	见选用件表 See op. Parts
18	D30K8-54024	Cap	2	
19	HRF339093 24459-42271	Seal	2	防尘圈d45
20	HRD20B8406 D28B8-42611	U-ring	2	U型密封圈D40
21	Z6003-06803	O-ring	2	O型密封圈53X2.65
22	D20B8-42341	Plug	2	塞子
23	H26A8-42011	Sleeve	2	衬套
24	D28B8-42461	Bushing	2	钢背轴承
25	HRD30K0514	Cylinder R.H.	1	见选用件表 See op. Parts
-	HRD30K0513	Cylinder L.H.	1	见选用件表 See op. Parts
26	HRD30K0515	Spacer	2	见选用件表 See op. Parts



图66/FIG. 66

后起升油缸 (二级全自由 3.5t) / REAR LIFT CYLINDER (FULL FREE 2-STAGE MAST ZM)

CPC, CPCD35

序号 Item No	图号 Part No	零部件名称 Description	件数 Q'ty	备注 Remark
27	REF340369 27978-42421	Wearing 支承环	2	
28	H22N0-87041	Sleeve 套筒	1	
29	H22N0-87051	Poppet 阀芯	1	
30	REF339431 53658-43031	Spring 弹簧	1	
31	H22N0-87061	Spring seat 弹簧座	1	
32	Z6004-04003	O-ring O型密封圈40X3.5	1	GB1235-76
33	H22N0-87071	Seat 底座	1	
34	B3130-10026	Pin 销 $\varnothing 10 \times 26$	1	GB119-86
35	D30K8-54011	Snap ring 挡片	1	
36	Q/ZB223.2	Plug 螺塞1/4"	2	

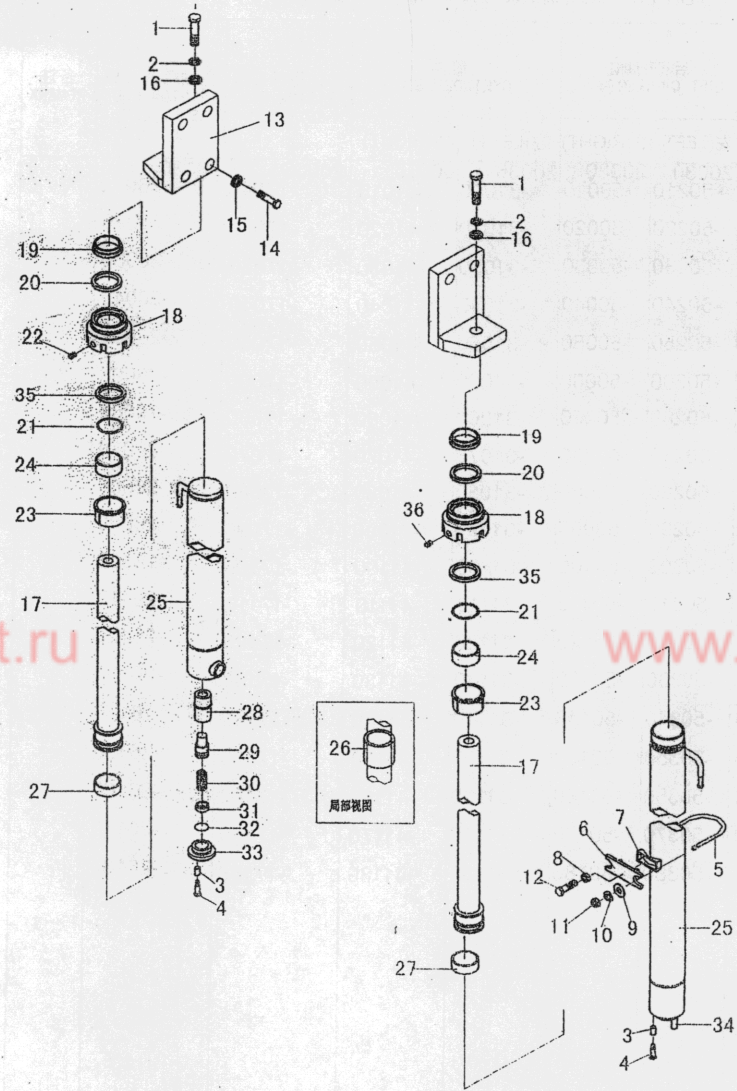