

图 35 倾斜油缸管路
Fig. 35 Tilting cylinder oil pipe

2008.3-
2008. 3-

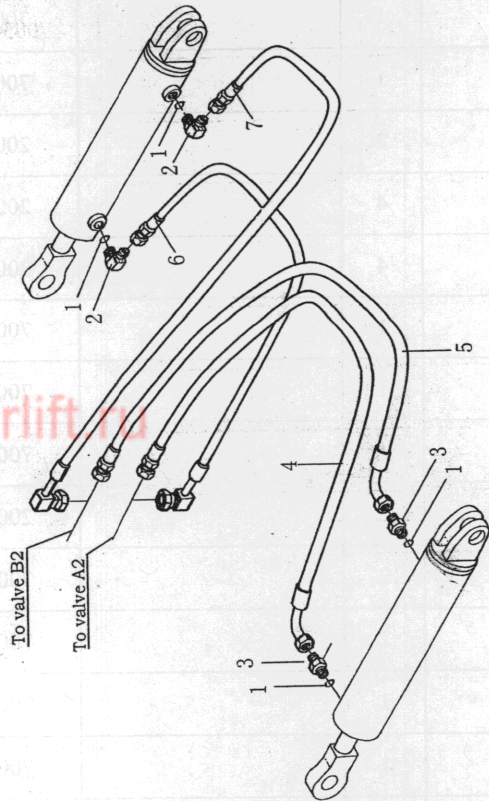

序号 Item No.	代号 Part No.	名称 Description	数量 Q'ty	备注或适用车型 Remarks or Series No.	物料码 Code No.
1	JISB2401-P11-G00	O形密封圈 P11 O-Ring P11	4		
2	N163-620800-000	90° 管接头 Connector	2		
3	JS160-660500-000	直通管接头 Connector	2		
4	JP300-600009-001	胶管总成 Hose	1		
5	JP300-600010-001	胶管总成 Hose	1		
6	JP300-600008-001	胶管总成 Hose	1		
7	JP300-600007-001	胶管总成 Hose	1		

图 36
Fig.36



物料码
Code No.

20000785

20000054

20000240

11000147

20000026

20000107

70025394

11000953

图 34 倾斜油缸管路
Fig. 34 Tilting cylinder oil pipe

-2008.3

-2008.3

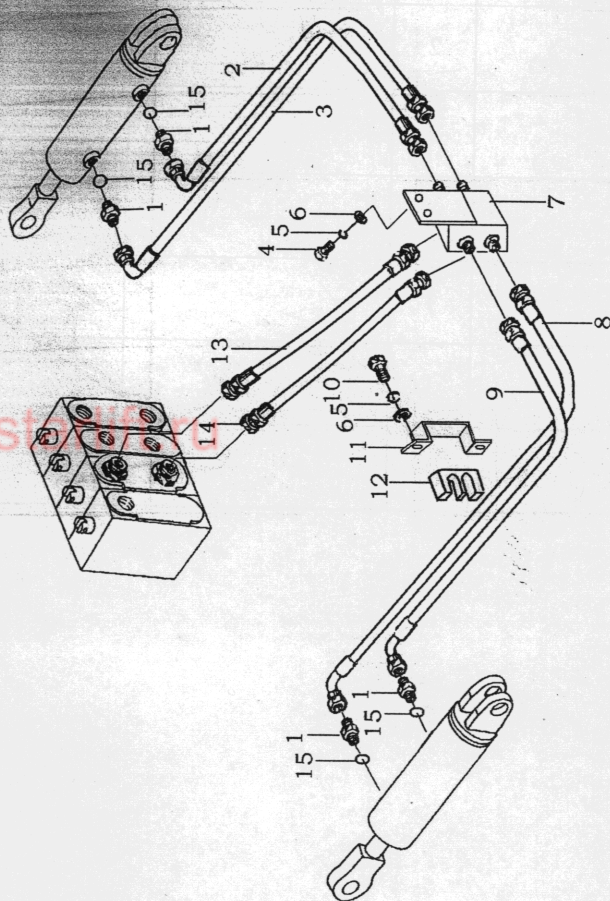

序号 Item No.	代号 Part No.	名称 Description	数量 Q'ty	备注或适用车型 Remarks or Series No.	物料码 Code No.
1	N163-620701-000	直通接头 Connector	4		70022388
2	JP300-600008-000	胶管总成 Hose	1		70034474
3	JP300-600007-000	胶管总成 Hose	1		70034473
4	GB5783-86	螺栓 M6×20 Bolt M6×20	2		20000010
5	GB93-87	垫圈 6 Washer 6	4		20000054
6	GB97.1-85	垫圈 6 Washer 6	4		20000785
7	JP300-630000-000	接头支座 Connector	1		70034488
8	JP300-600009-000	胶管总成 Hose	1		70034475
9	JP300-600010-000	胶管总成 Hose	1		70034476
10	GB5783-86	螺栓 M6×16 Bolt M6×16	2		20000240
11	JP300-600013-000	固定夹 Clip	2		70034485
12	JP300-600012-000	橡胶固定块 Rubber	2		70034484
13	JP300-600016-000	胶管总成 Hose	1		70034493
14	JP300-600017-000	胶管总成 Hose	1		70034494
15	JISB2401-P11-G00	O形密封圈 P11 O-Ring P11	4		11007272

图 33 液压管路
Fig. 33 Hydraulic system

2008.3-
2008.3-

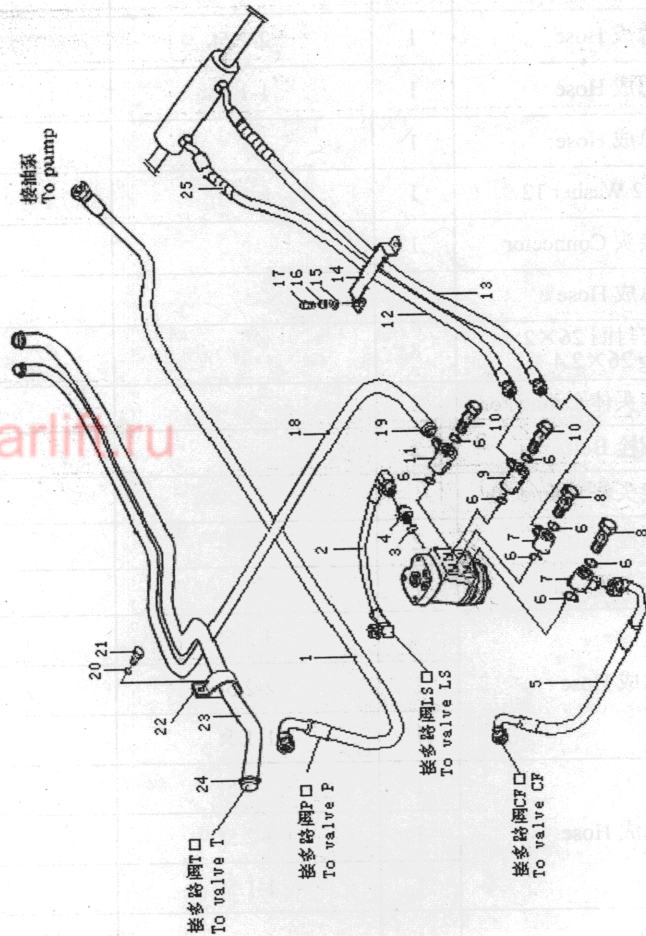

序号 Item No.	代号 Part No.	名称 Description	数量 Q'ty	备注或适用车型 Remarks or Series No.	物料码 Code No.
15	GB97.1-85	垫圈 6 Washer 6	2		20000785
16	GB93-87	垫圈 6 Washer 6	2		20000054
17	GB5783-86	螺栓 M6×16 Bolt M6×16	2		20000240
18	JP300-600004-W00	低压胶管 Hose	1	3-3.5t	
	JP250-600004-W00		1	2-2.5t	
	JP150-600004-W00		1	1-1.5t	
19	Q672-24-G00	双钢丝式环箍 24 Clamp 24	2		11000147
20	GB93-87	垫圈 8 Washer 8	1		20000026
21	GB5783-86	螺栓 M8×16 Bolt M8×16	1		20000107
22	JS160-600003-000	管带 Strip	1		70025394
23	JP300-600011-000	回油管 Hose	1	3-3.5t	
	JP250-600011-000		1	2-2.5t	
	JP150-600011-000		1	1-1.5t	
24	Q672-45-G00	双钢丝式环箍 45 Clamp 45	2		11000953
25	JP300-600018-W00	护套 (Φ17×1) Nylon (Φ17×1)	2		

图
Fig

物料码
Code No.
20000026
20000107
70025394
70034483
70036471
70038957
11000953

图 33 液压管路
Fig. 33 Hydraulic system

2008.3-
2008.3-

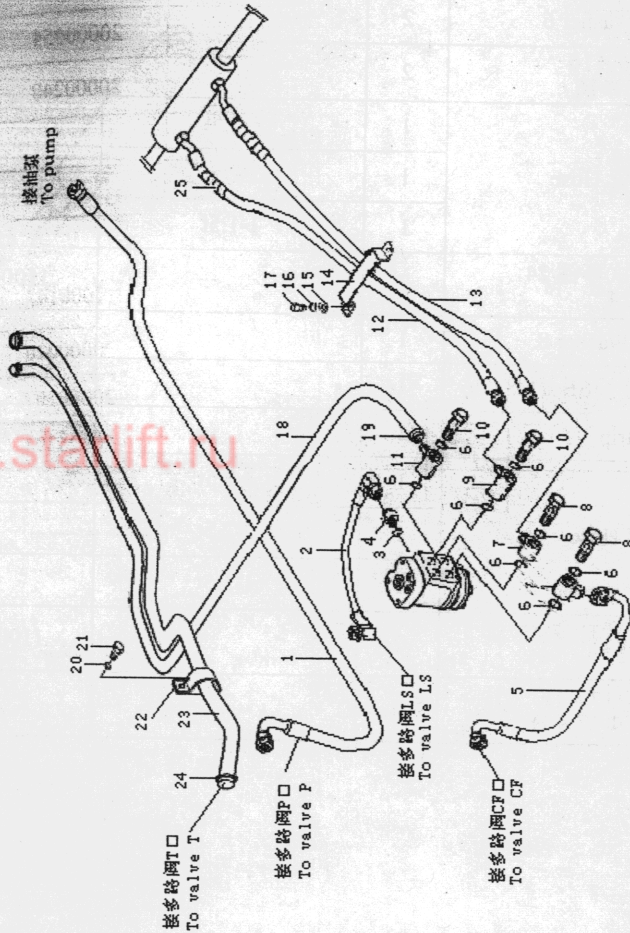

序号 Item No.	代号 Part No.	名称 Description	数量 Q'ty	备注或适用车型 Remarks or Series No.	物料码 Code No.
1	JP300-600002-001	胶管总成 Hose	1	3-3.5t	
	JP300-600002-000	胶管总成 Hose	1	2-2.5t	
	JP250-600002-000	胶管总成 Hose	1	1-1.5t	
2	JP451-600012-001	胶管总成 Hose	1		
3	JB982-77	垫圈 12 Washer 12	1		
4	JP451-600003-001	直通接头 Connector	1		
5	JP451-600013-001	胶管总成 Hose	1		
6	GB1235-76	O形密封圈 26×2.4 O-Ring 26×2.4	8		
7	30DH-600010	铰接接头体 Connector	2		
8	3-60-00-04	铰接螺栓 Bolt	2		
9	30DH-600012	铰接接头体 Connector	1		
10	3-60-00-02	铰接螺栓 Bolt	2		
11	30DH-600011	接头体 Connector	1		
12	JP300-600004-001	胶管总成 Hose	1	3-3.5t	
	JP300-600005-000		1	2-2.5t	
	JP250-600005-000		1	1-1.5t	
13	JP300-600005-000	胶管总成 Hose	1	3-3.5t	
	JP250-600005-000		1	2-2.5t	
	JP150-600005-000		1	1-1.5t	
14	JP300-600015-000	管夹 Clip	1		70034487

图 32 液压管路 -2008.3
Fig. 32 Hydraulic system -2008.3

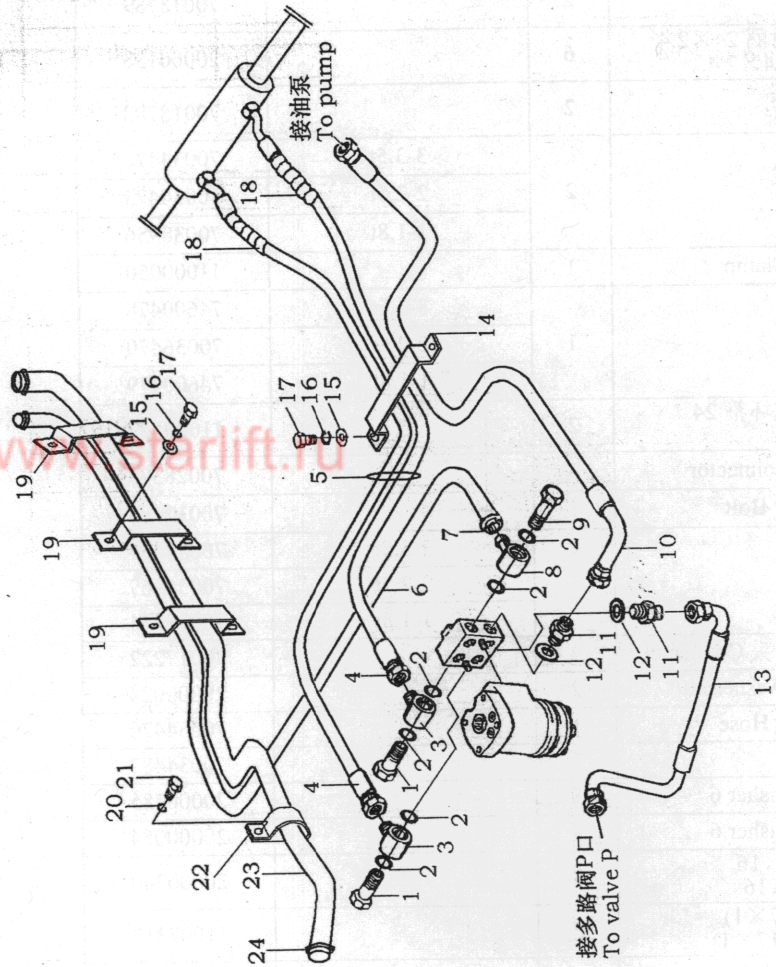

序号 Item No.	代号 Part No.	名称 Description	数量 Q'ty	备注或适用车型 Remarks or Series No.	物料码 Code No.
20	GB93-87	垫圈 8 Washer 8	1		20000026
21	GB5783-86	螺栓 M8×16 Bolt M8×16	1		20000107
22	JS160-600003-000	管带 Strip	1		70025394
23	JP300-600011-000	回油管 Hose	1	3-3.5t	70034483
	JP250-600011-000			2-2.5t	70036471
	JP150-600011-000			1-1.8t	70038957
24	Q672-45-G00	双钢丝式环箍 45 Clamp 45	2		11000953

图 33
Fig. 33 Hy

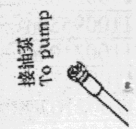

20 21

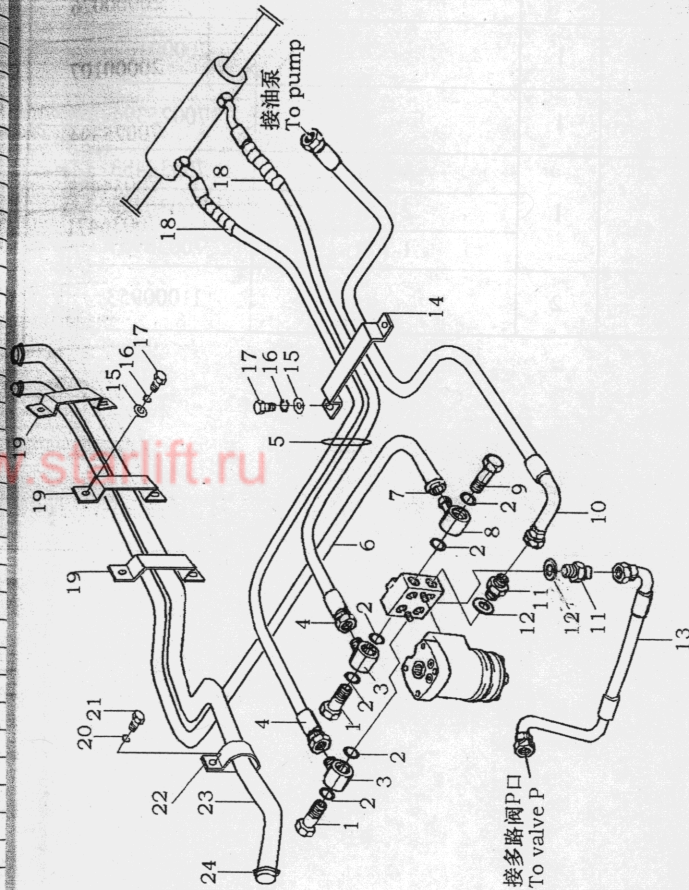
物料码
Code No.1100210301
11009550011100210302
11009550021100210303
11009550031100210304
11009550041100210305
11009550051100210306
11009550061100210307
11009550071100210308
11001864011100955008
11010354011100210309
11001864021100955009
11010354021100210310
11001864031100955010
11010354031100210311
11002103121100955012
11002103131100210314
11009550141100210315
11001864041100955015
1101035404图 32 液压管路 -2008.3
Fig. 32 Hydraulic system -2008.3

序号 Item No.	代号 Part No.	名称 Description	数量 Q'ty	备注或适用车型 Remarks or Series No.	物料码 Code No.
1	14RH-600005	铰接螺栓 Bolt	2		70018789
2	GB1235-76	O形密封圈 24×2.4 O-Ring 24×2.4	6		20000138
3	14RH-600004	铰接接头 Connector	2		70018788
4	JP300-600005-000	胶管总成 Hose	2	3-3.5t	70034472
	2-2.5t			70036473	
	1-1.8t			70038956	
5	PKD-180-G00	捆线带 Clamp	1		11000050
6	JP300-600004-W00	低压胶管 Hose	1	3-3.5t	74600478
	2-2.5t			70036470	
	1-1.8t			74600479	
7	Q672-24-G00	双钢丝式环箍 24 Clamp 24	2		11000147
8	JS160-650003-000	接头体 Connector	1		70028373
9	25PH-600009	铰接螺栓 Bolt	1		70012183
10	JP300-600002-000	胶管总成 Hose	1	3-3.5t	70034469
	2-2.5t			70036469	
	1-1.8t			70038954	
11	14RH-600002	直通管接头 Connector	2		70017222
12	JB982-77	垫圈 20 Washer 20	2		20000024
13	JP300-600003-000	胶管总成 Hose	1		70034470
14	JP300-600015-000	管夹 Clip	1		70034487
15	GB97.1-85	垫圈 6 Washer 6	8		20000785
16	GB93-87	垫圈 6 Washer 6	8		20000054
17	GB5783-86	螺栓 M6×16 Bolt M6×16	8		20000240
18	N163-630001-W00	护套(Φ17×1) Nylon(Φ17×1)	2		11007319
19	JP300-600014-000	管夹 Clip	3		70034486