

轮式制动器  
Wheel brake

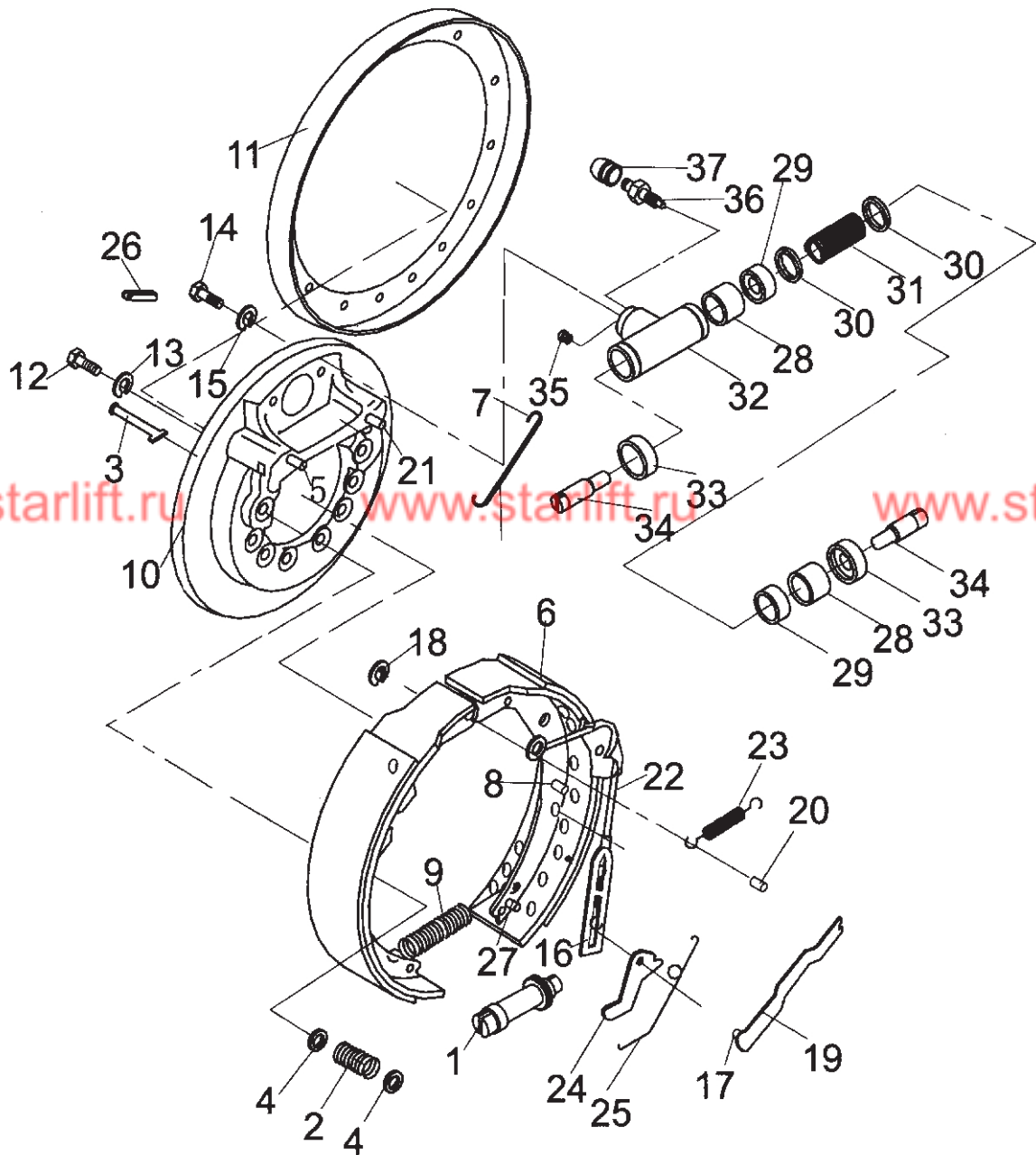

## 轮式制动器 Wheel brake

序号 Item	零件号 Part No	零部件名称 Description	数量 Q'ty	备注 Remark
A	A50A5-04000(L)	制动器总成 (左) Wheel brake	1	FD50,60,70BG-CY1/W3
-	A50E5-00500(L)	制动器总成 (左) Wheel brake	1	FD50,60,70BG-S3
-	A50A5-04000(R)	制动器总成 (右) Wheel brake	1	FD50,60,70BG-CY1/W3
-	A50E5-00500(R)	制动器总成 (右) Wheel brake	1	FD50,60,70BG-S3
1	A50A5-04001	调整器总成 Adjuster ass'y	1	
2	A50A5-04002	弹簧F Spring	2	
3	A50A5-04003	压簧拉杆 Pin,shoe hold down	2	
4	A50A5-04004	压簧座 Cup,shoe hold down	4	
5	A50A5-04005	销 Pin	2	
6	A50A5-04006	制动蹄带磨擦片总成 Shoe pin & lining ass'y	2	
7	A50A5-04007	弹簧E Spring	1	
8	A50A5-04008	销 Pin	1	
9	A50A5-04009	弹簧B Spring	1	
10	A50A5-04010	制动器底板 Backboard,brake	1	
11	A50A5-04011	罩壳 Sheald dust	1	
12	A50A5-04012	螺栓 Bolt	6	
13	GB/T93-1987	弹垫6 Washer,lock	6	
14	GB/T5782-2000	螺栓M8×45 Bolt	2	
15	GB/T93-1987	弹垫6 Washer.lock	2	
16	A50A5-04013	弹簧铆接装置 Spring joint unit	1	
17	GB/T91-2000	销1.6×16 Pin	1	
18	A50A5-04014	垫圈 Washer	1	
19	A50A5-04015	摇臂 Link	1	
20	A50A5-04016	销 Pin	1	

轮式制动器  
Wheel brake

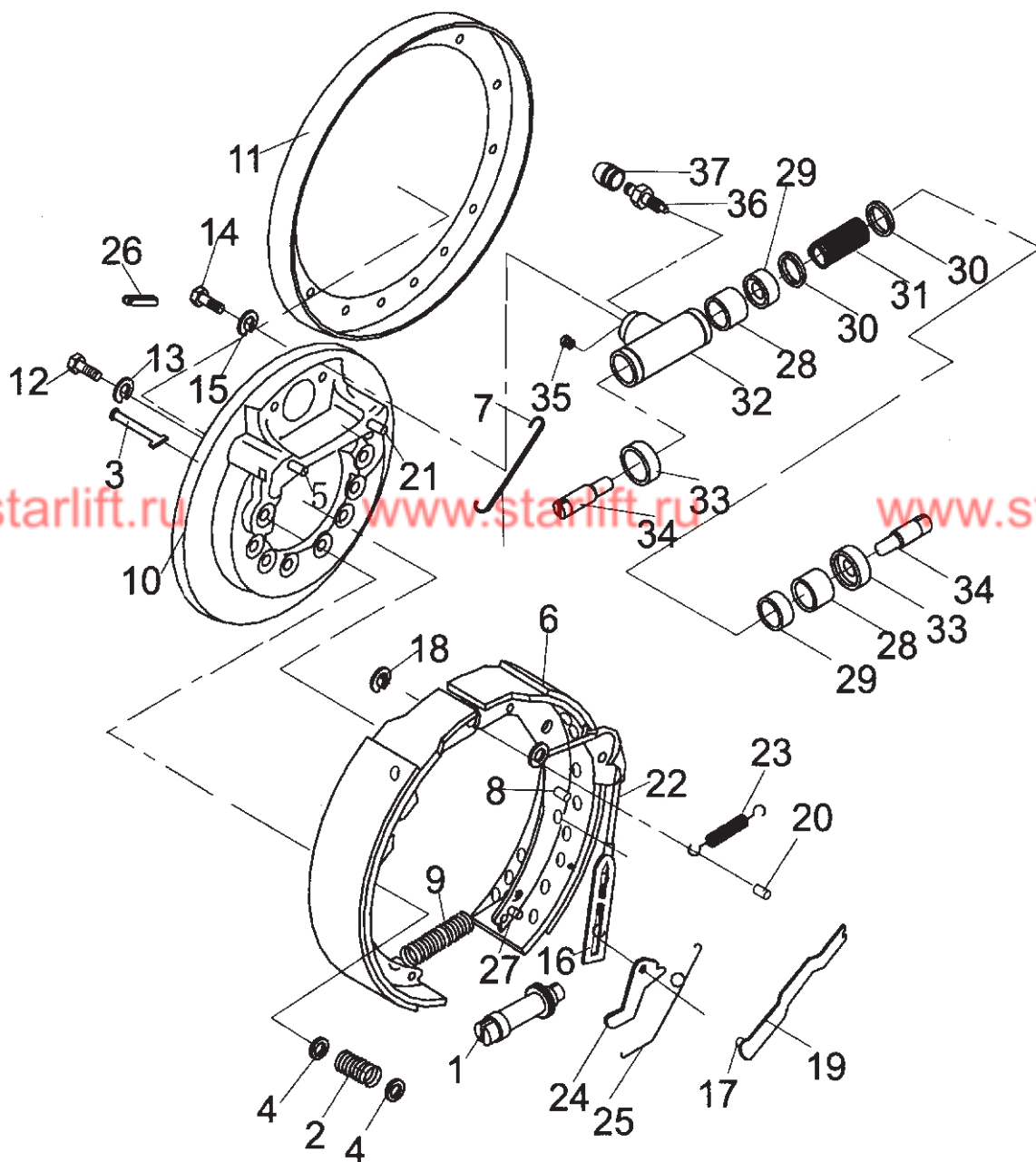

## 轮式制动器 Wheel brake

序号 Item	零件号 Part No	零部件名称 Description	数量 Q'ty	备注 Remark
21	A50A5-04017	销 Pin	1	
22	A50A5-04018	上拉杆 Lever	1	
23	A50A5-04019	弹簧A Spring	1	
24	A50A5-04020	棘爪 Lever	1	
25	A50A5-04021	弹簧G Spring	1	
26	A50A5-04022	堵塞 Cover.adjusting hole	1	
27	A50A5-04023	销 Pin	1	
B	A50A5-05000	制动分泵总成 Wheel cylinder ass'y	1	FD50,60,70BG-CY1/W3
-	A50A5-00600	制动分泵总成 Wheel cylinder ass'y	1	FD50,60,70BG-S3
28	A50A5-05001	分泵活塞 Piston	2	
29	A50A5-05002	密封垫 Sealing washer	2	FD50,60,70BG-CY1/W3
-	A50E5-00601	密封垫 Sealing washer	2	FD50,60,70BG-S3
30	A50A5-05003	分泵皮碗 Cup, piston	2	FD50,60,70BG-CY1/W3
-	A50E5-00602	分泵皮碗 Cup, piston	2	FD50,60,70BG-S3
31	A50A5-05004	分泵弹簧 Spring	1	
32	A50A5-05005	制动分泵缸 Cylinder	1	
33	A50A5-05006	分泵护罩 Cover, dust	2	
34	A50A5-05007	分泵活塞顶杆 Rod, piston	2	
35	A50A5-05008	制动分泵油塞 Plug	1	
36	A50A5-05009	分泵放气螺钉 Screw, breather	1	
37	A50A5-05010	分泵放气螺钉帽 Cap, screw	1	