

门架管路系统（基本型）  
Hydraulic system mast(Normal mast KM)

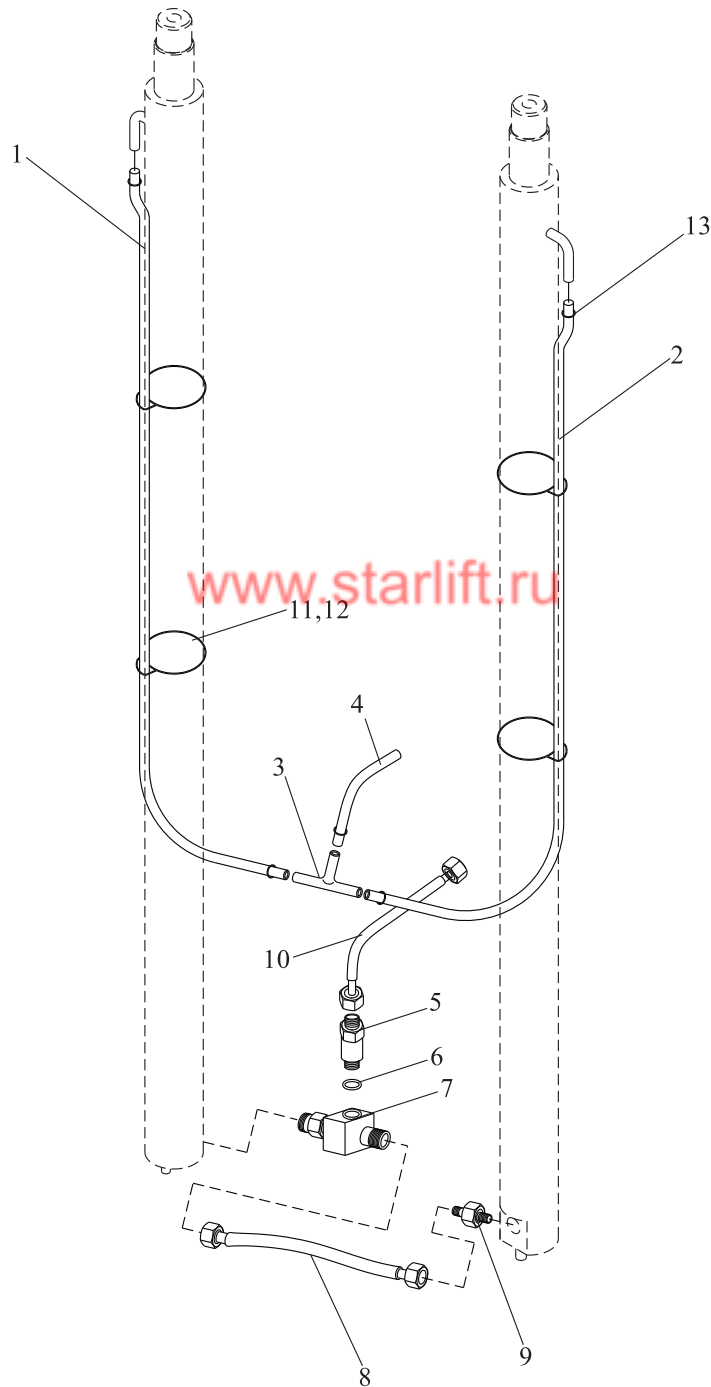

门架管路系统（基本型）  
Hydraulic system mast(Normal mast KM)

序号 Item	零件号 Part No	零部件名称 Description	数量 Q'ty	备注 Remark
1	TG000-120XX	塑料管d12×L1 Tube vinyl	1	
2	TG000-120XX	塑料管d12×L2 Tube vinyl	1	
3	GJT-01-00	回油接头 Joint	1	
4	TG000-12110	塑料管d12×1100 Tube vinyl	1	
5	GJT-02-00	限速阀 Flow regulator	1	
6	JB982-1977	组合垫圈22×2.7 Washer	1	
7	GJT-03-00C	三通接头总成 Three way connector ass'y	1	2-3t
-	GJT-80-00	三通接头总成 Three way connector ass'y	1	3.5t
8	TGIBII-13039*J	高压胶管13II×390 Hose H.P.	1	
9	GJT-04-00	切断阀 Valve,check	1	2-3t
-	GJT-81-00	直通接头 Nipple	1	3.5t
10	TGIBII-13056GS*J	高压胶管13II×560 Hose H.P.	1	2-2.5t
-	TGIBII-13060GS*J	高压胶管13II×600 Hose H.P.	1	3-3.5t
11	M30A3-70001	管夹片 Band	4	
12	TQ000-05035	扎带5×350 Binding	4	
13	Tk000-10016	卡箍10×16 Clip	6	

门架管路系统（基本型）  
Hydraulic system mast(Normal mast KM)

管路系统选用件（Mast Piping Optional Parts）					
起升高度 Lifting Height	件1长度 Hose(mm)		件2长度 Hose(mm)		备注 Remark
	2-3t	3.5t	2-3t	3.5t	
2000	1000	1100	900	1000	
2500	1200	1300	1100	1200	
2700	1300	1400	1200	1300	
3000	1400	1500	1350	1450	标准
3300	1600	1700	1500	1600	
3500	1700	1800	1600	1700	
3700	1800	1900	1700	1800	
4000	2000	2100	1900	2000	
4250	2100	2200	2000	2100	
4500	2300	2400	2150	2250	
4750	2400	2500	2300	2400	
5000	2500	2600	2400	2500	
5500	2800	2900	2700	2800	
6000	3100	3200	2950	3150	

门架管路系统（二节全自由）  
Hydraulic system mast(Full Free 2-Stage Mast KZM)

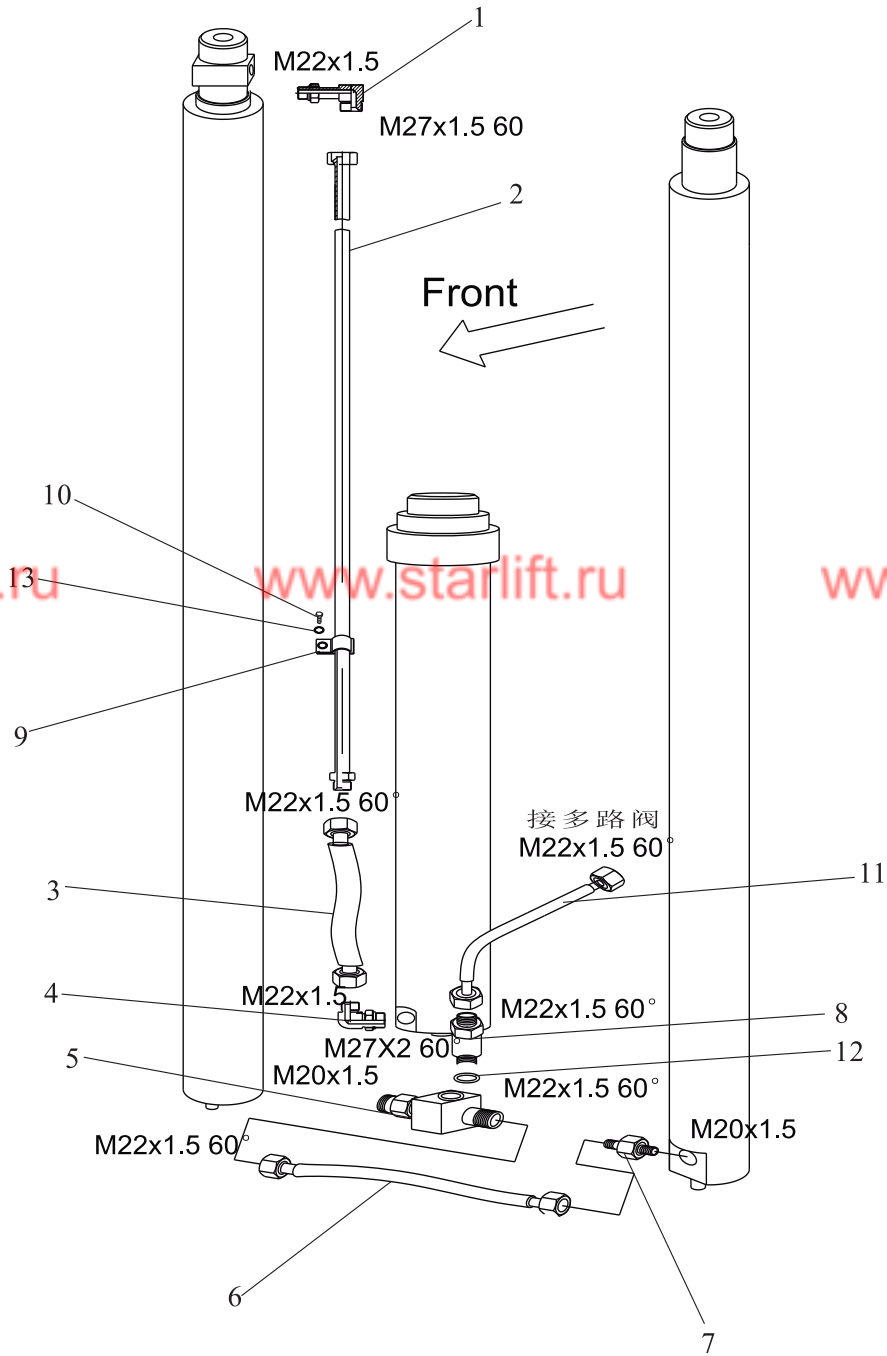

## 门架管路系统（二节全自由）

## Hydraulic system mast(Full Free 2-Stage Mast KZM)

序号 Item	零件号 Part No	零部件名称 Description	数量 Q'ty	备注 Remark
1	GJT-22-00	直角接头 Elbow	1	
2	GJT-23-00	钢管总成 Steel Pipe ass'y	1	
3	TGIBII-13056GS*J	高压胶管13II×560 Hose H.P.	1	
4	GJT-24-00	直角接头 Elbow	1	
5	GJT-03-00C	三通接头总成 Three way connector ass'y	1	
6	TGIBII-13039*J	高压胶管13II×390 Hose H.P.	1	
7	GJT-04-00	切断阀 Valve,check	1	
8	GJT-02-00	限速阀 Flow regulator	1	
9	Z30A3-70001	油管固定板 Board	1	
10	GB/T5782-2000	螺栓M8×20 Bolt	1	
11	TGIBII-13060GS*J	高压胶管13II×600 Hose H.P.	1	
12	JB962-77	组合垫圈22×2.7 Washer	1	
13	GB/T93-1987	弹垫 8 Washer,lock	1	

## 门架管路系统（二节全自由）

Hydraulic system mast(Full Free 2-Stage Mast KZM)

管路系统选用件（Mast Piping Optional Parts）		
起升高度 Lifting Height	件2长度 Hose(mm)	备注 Remark
2700	978	
3000	1128	标准
3300	1278	
3500	1378	
3700	1478	
4000	1678	

# 门架管路系统（三节全自由） Hydraulic system mast(Full Free 3-Stage Mast KZM)

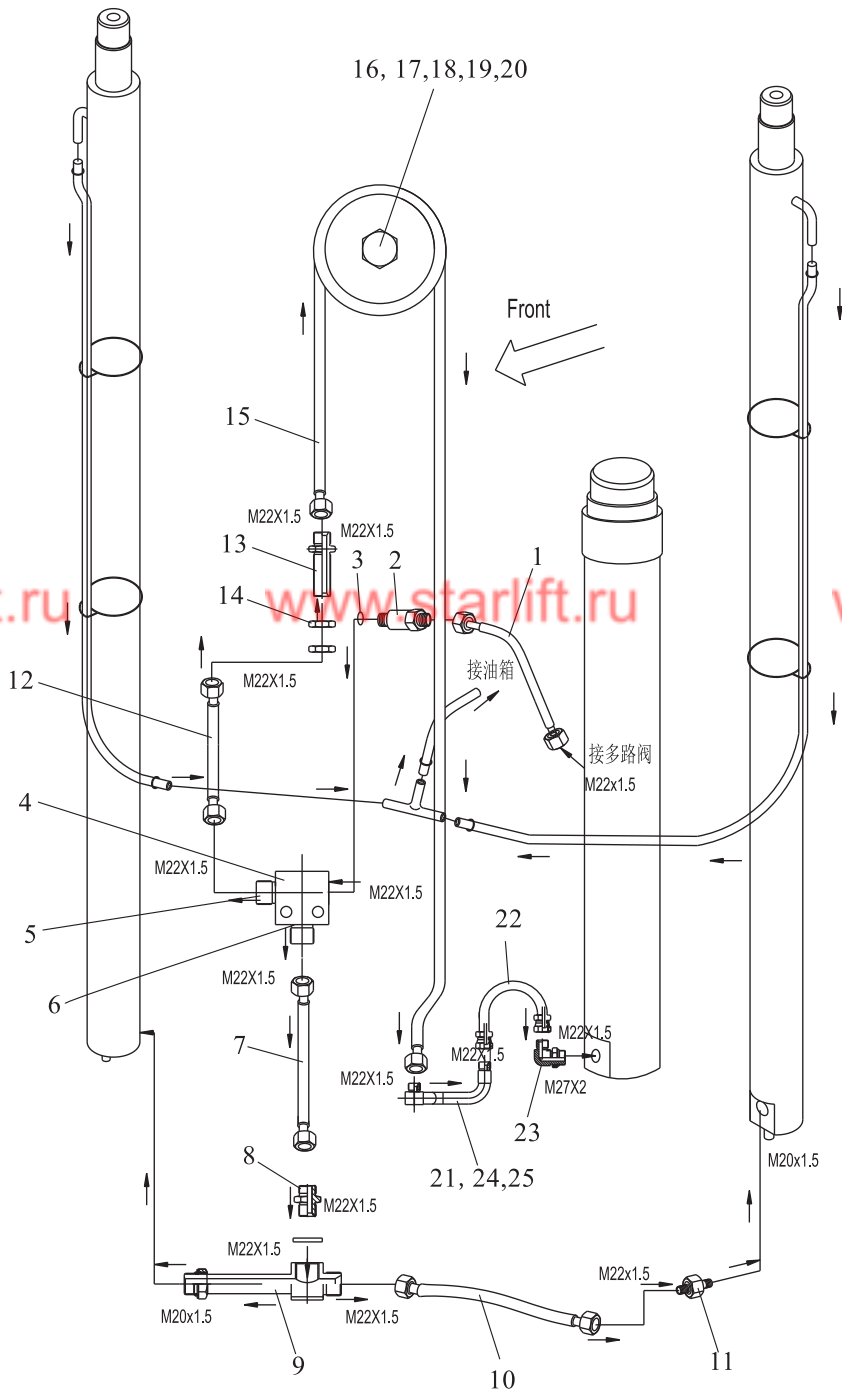

## 门架管路系统（三节全自由）

## Hydraulic system mast(Full Free 3-Stage Mast KZM)

序号 Item	零件号 Part No	零部件名称 Description	数量 Q'ty	备注 Remark
1	TGLBII-13075-H45GS*J	高压胶管13II×750 Hose H.P.	1	
2	GJT-02-00	限速阀 Flow regulator	1	
3	JB962-77	组合垫圈22×2.7 Washer	2	
4	GJT-61-00	三通接头 Three way connector	1	
5	GB/T5276-1985	螺母M8×1.25 Nut	2	
6	GB/T5785-1986	螺栓M8×1.25×50 Bolt	2	
7	TGIBII-13054NL*J	高压胶管13II×540 Hose H.P.	1	
8	GJT-26-00	直通接头 Nipple	1	
9	GJT-84-00	三通接头总成 Three way connector ass'y	1	
10	TGIBII-13033*J	高压胶管13II×330 Hose H.P.	1	
11	GJT-04-00	切断阀 Valve,check	1	
12	TGIBII-13041NL*J	高压胶管13II×410 Hose H.P.	1	
13	GJT-179-00	直通接头 Nipple	1	
14	GB/T5276-1985	螺母M22×1.25 Nut	2	
15	TGIBII-13XXX	高压胶管13IIXXX Hose H.P.	1	
16	S30C3-70001	滑轮 Pulley	1	
17	S30C3-70002	轴头 Spindle head	1	
18	GB/T894.1-1986	弹性挡圈Φ20 Ring	1	
19	GB/T5785-1986	螺栓M12×1.25×55 Bolt	2	
20	GB276-94	轴承61904-2Z Bushing	1	
21	GJT-110-00	钢管总成 Steel Pipe ass'y	1	
22	TGIBII-13040NL*J	高压胶管13II×400 Hose H.P.	1	
23	GJT-24-00	直角接头 Elbow	1	
24	GB/T5785-1986	螺栓M10×1.5×30 Bolt	2	
25	GB/T93-1987	弹垫 10 Washer,lock	2	



## 门架管路系统（三节全自由）

Hydraulic system mast(Full Free 3-Stage Mast KZM)

管路系统选用件（Mast Piping Optional Parts）			
起升高度 Lifting Height	件15长度 Hose(mm)		备注 Remark
	3t	2-2.5t	
3700	2000	1900	
4000	2100	2000	
4350	2450	2350	
4500	2550	2450	标准
4800	2700	2600	
5000	2850	2750	
5500	3250	3150	
6000	3550	3450	

货叉  
Fork

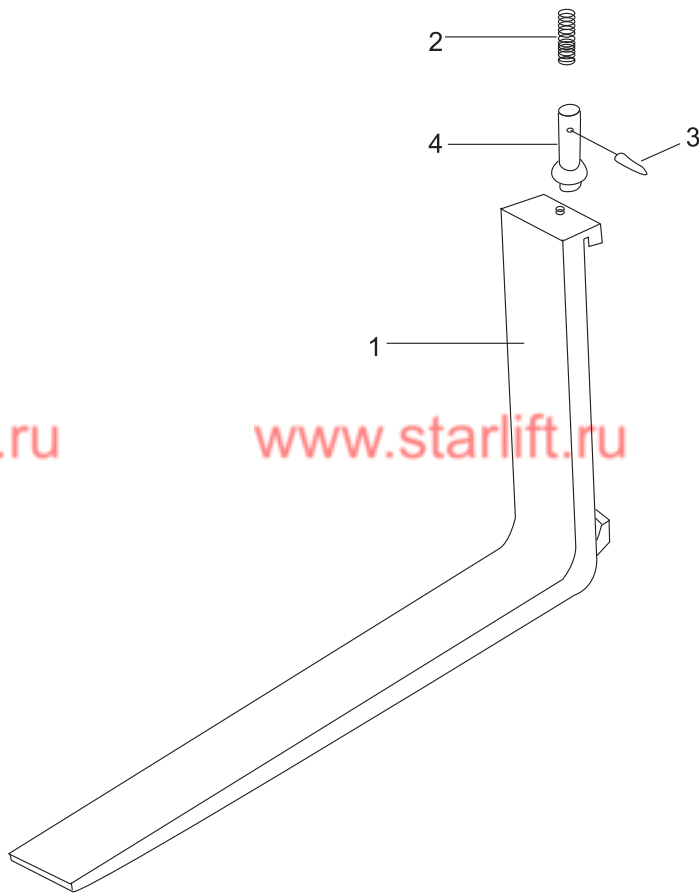

货叉  
Fork

序号 Item	零件号 Part No	零部件名称 Description	数量 Q'ty	备注 Remark
1	A30A3-90000	货叉总成 Fork ass'y	2	3t
	A20A3-90000	货叉总成 Fork ass'y	2	2-2.5t
	A35A3-90000	货叉总成 Fork ass'y	2	3.5t
2	A30A3-90001	弹簧 Spring	2	3t
	A20A3-90001	弹簧 Spring	2	2-2.5t
	A35A3-90001	弹簧 Spring	2	3.5t
3	A30A3-90002	销 Pin	2	3t
	A20A3-90002	销 Pin	2	2-2.5t
	A35A3-90002	销 Pin	2	3.5t
4	A30A3-90003	止动销子 Pin, stopper	2	3t
	A20A3-90003	止动销子 Pin, stopper	2	2-2.5t
	A35A3-90003	止动销子 Pin, stopper	2	3.5t

货叉架（基本型）  
Lift Bracket Normal Mast

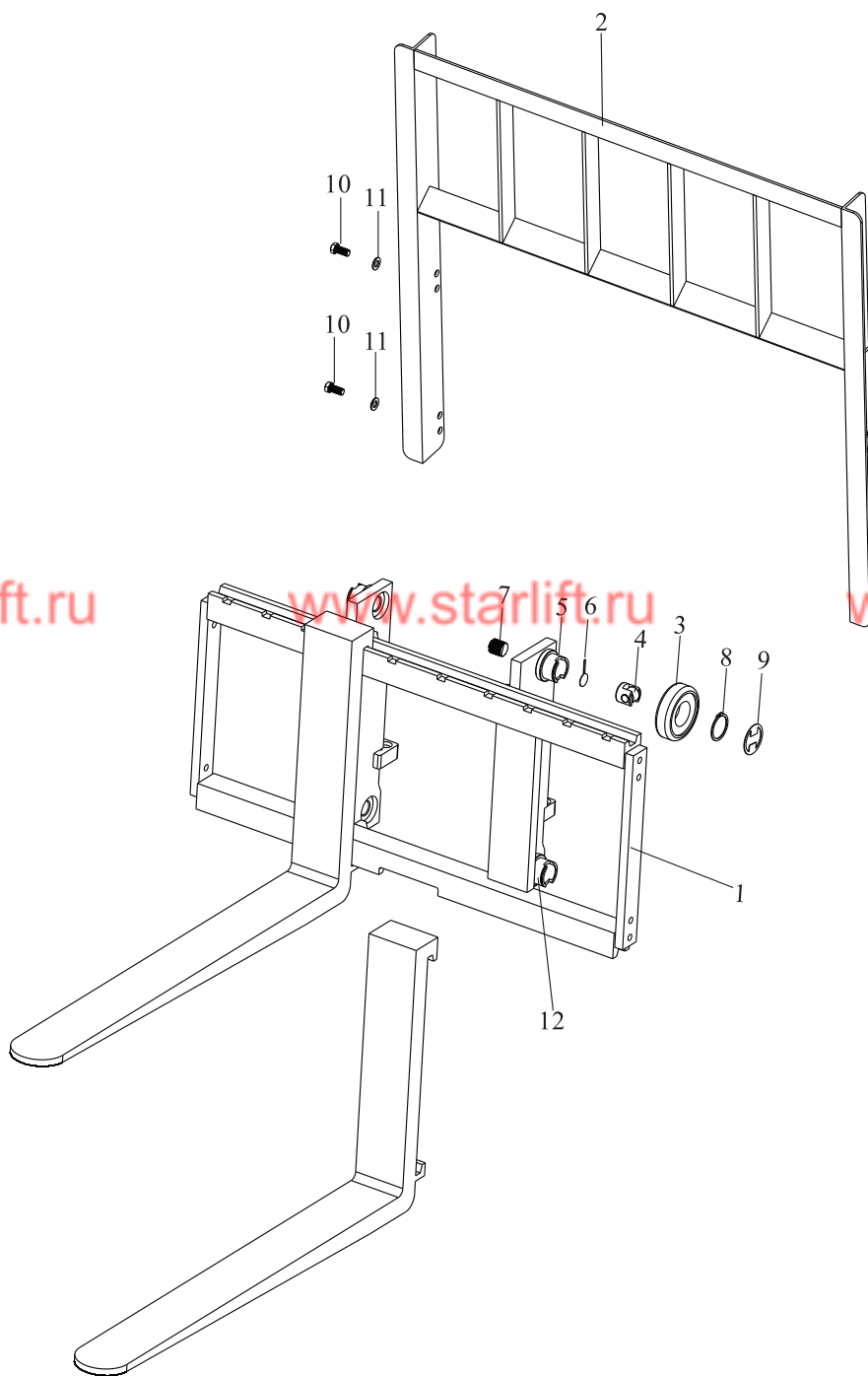

## 货叉架（基本型）

## Lift Bracket Normal Mast

序号 Item	零件号 Part No	零部件名称 Description	数量 Q'ty	备注 Remark
1	M30A3-50000	货叉架总成 Lifting fork ass'y	1	3t
	M20A3-50000	货叉架总成 Lifting fork ass'y	1	2-2.5t
	M35A3-50000	货叉架总成 Lifting fork ass'y	1	3.5t
2	M30A3-60000	挡货架总成 Backrest ass'y	1	3-3.5t
	M20A3-60000	挡货架总成 Backrest ass'y	1	2-2.5t
3	M30A3-40301	主滚轮 End Roller	6	
4	M30A3-40302	侧滚轮 Side roller	6	
5	M30A3-50103	滚轮轴 Shaft roller	2	
6	M30A3-40304	止松片 Loose slice	6	
7	M30A3-40305	调节螺钉 Screw	6	
8	M30A3-40306	轴用挡圈 Snap,ring	6	
9	M30A3-40307	防尘片 Dust-Proof ring	6	
10	GB/T5782-1986	螺栓M14×25 Bolt	8	
11	GB/T93-1987	弹垫14 Washer, lock	8	
12	M30A3-30005	滚轮轴 Shaft roller	4	

货叉架（二节全自由）  
Lift Bracket Full Free 2-Stage Mast

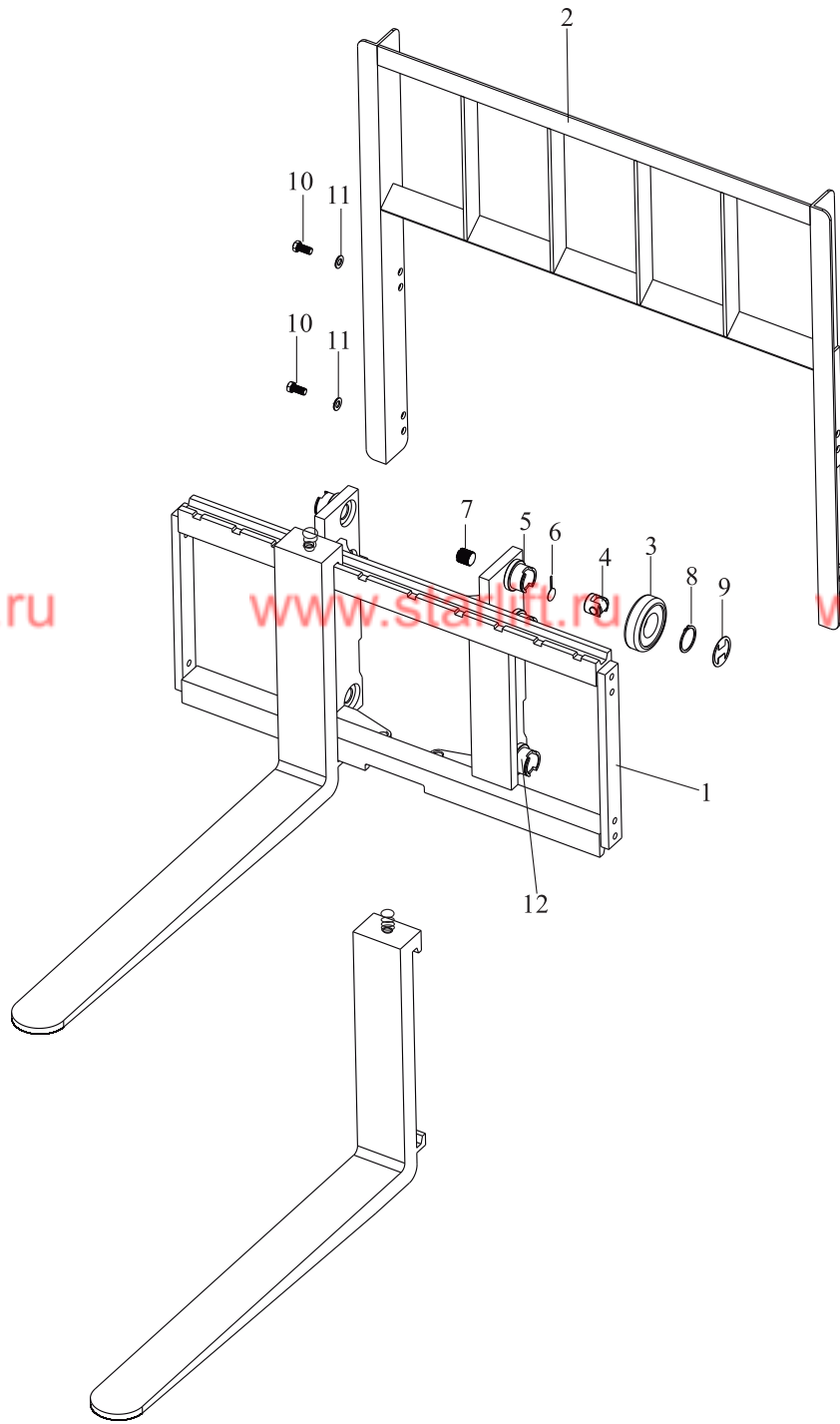

www.starlift.ru

www.starlift.ru

www.starlift.ru

## 货叉架（二节全自由）

## Lift Bracket Full Free 2-Stage Mast

序号 Item	零件号 Part No	零部件名称 Description	数量 Q'ty	备注 Remark
1	Z30A3-50000	货叉架总成 Lifting fork ass'y	1	3t
	Z20A3-50000	货叉架总成 Lifting fork ass'y	1	2-2.5t
	Z35A3-50000	货叉架总成 Lifting fork ass'y	1	3.5t
2	M30A3-60000	挡货架 Backrest	1	3-3.5t
	M20A3-60000	挡货架 Backrest	1	2-2.5t
3	M30A3-40301	主滚轮 End Roller	6	
4	M30A3-40302	侧滚轮 Side roller	6	
5	M30A3-50103	滚轮轴 Shaft roller	2	
6	M30A3-40304	止松片 Loose slice	6	
7	M30A3-40305	调节螺钉 Screw	6	
8	M30A3-40306	轴用挡圈 Snap,ring	6	
9	M30A3-40307	防尘片 Dust-Proof ring	6	
10	GB/T5782-1986	螺栓M14×25 Bolt	8	
11	GB/T93-1987	弹垫14 Washer, lock	8	
12	M30A3-30005	滚轮轴 Shaft roller	4	

货叉架（三节全自由）  
Lift Bracket Full Free 3-Stage Mast

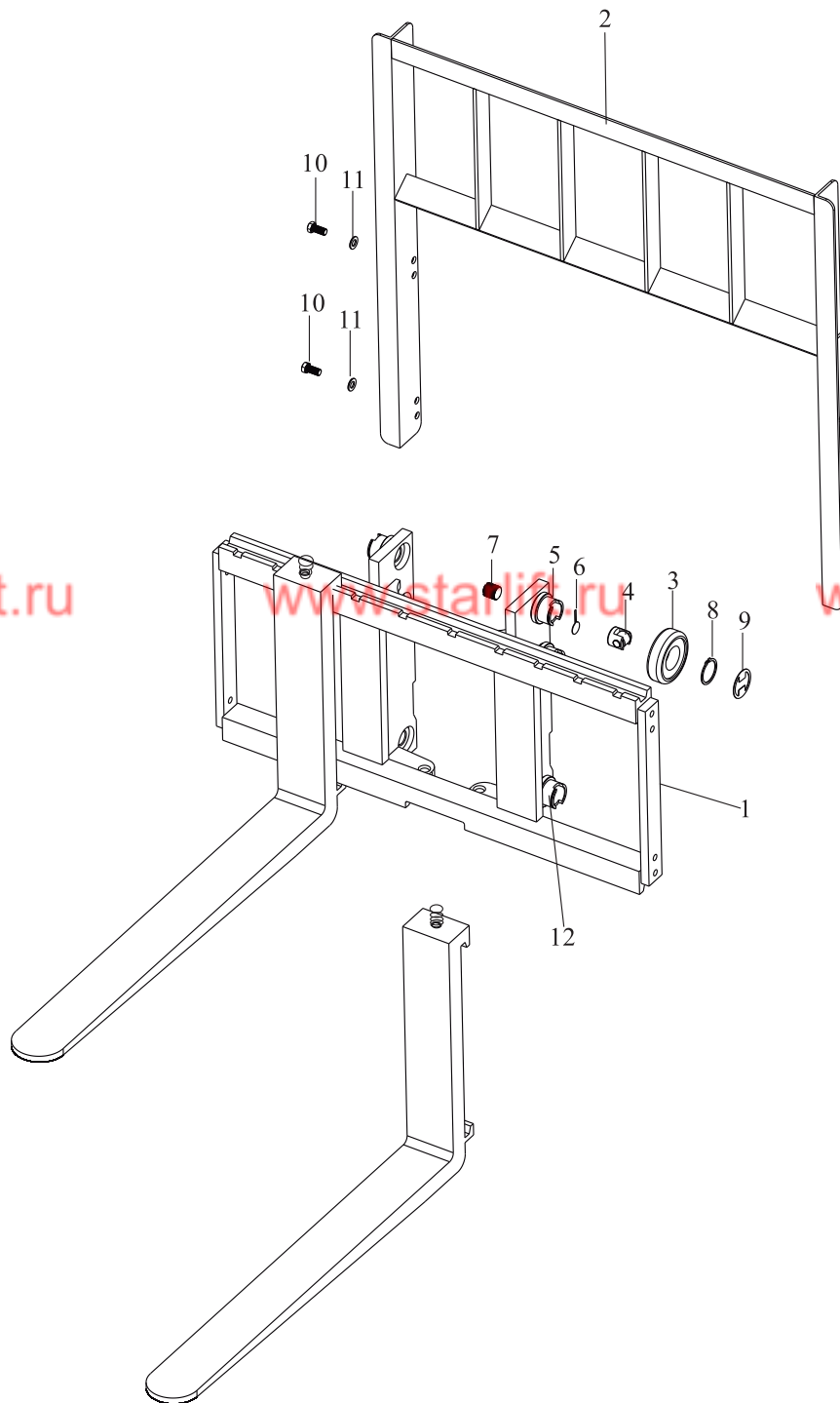



## 货叉架（三节全自由）

## Lift Bracket Full Free 3-Stage Mast

序号 Item	零件号 Part No	零部件名称 Description	数量 Q'ty	备注 Remark
1	S30C3-50000	货叉架总成 Lifting fork ass'y	1	3t
	S20C3-50000	货叉架总成 Lifting fork ass'y	1	2-2.5t
2	M30A3-60000	挡货架 Backrest	1	3t
	M20A3-60000	挡货架 Backrest	1	2-2.5t
3	M30A3-40301	主滚轮 End Roller	6	
4	M30A3-40302	侧滚轮 Side roller	6	
5	M30A3-50103	滚轮轴 Shaft roller	2	
6	M30A3-40304	止松片 Loose slice	6	
7	M30A3-40305	调节螺钉 Screw	6	
8	M30A3-40306	轴用挡圈 Snap,ring	6	
9	M30A3-40307	防尘片 Dust-Proof ring	6	
10	GB/T5782-1986	螺栓M14×25 Bolt	8	
11	GB/T93-1987	弹垫14 Washer, lock	8	
12	M30A3-30005	滚轮轴 Shaft roller	4	

门架(基本型)  
Mast (Normal mast KM)

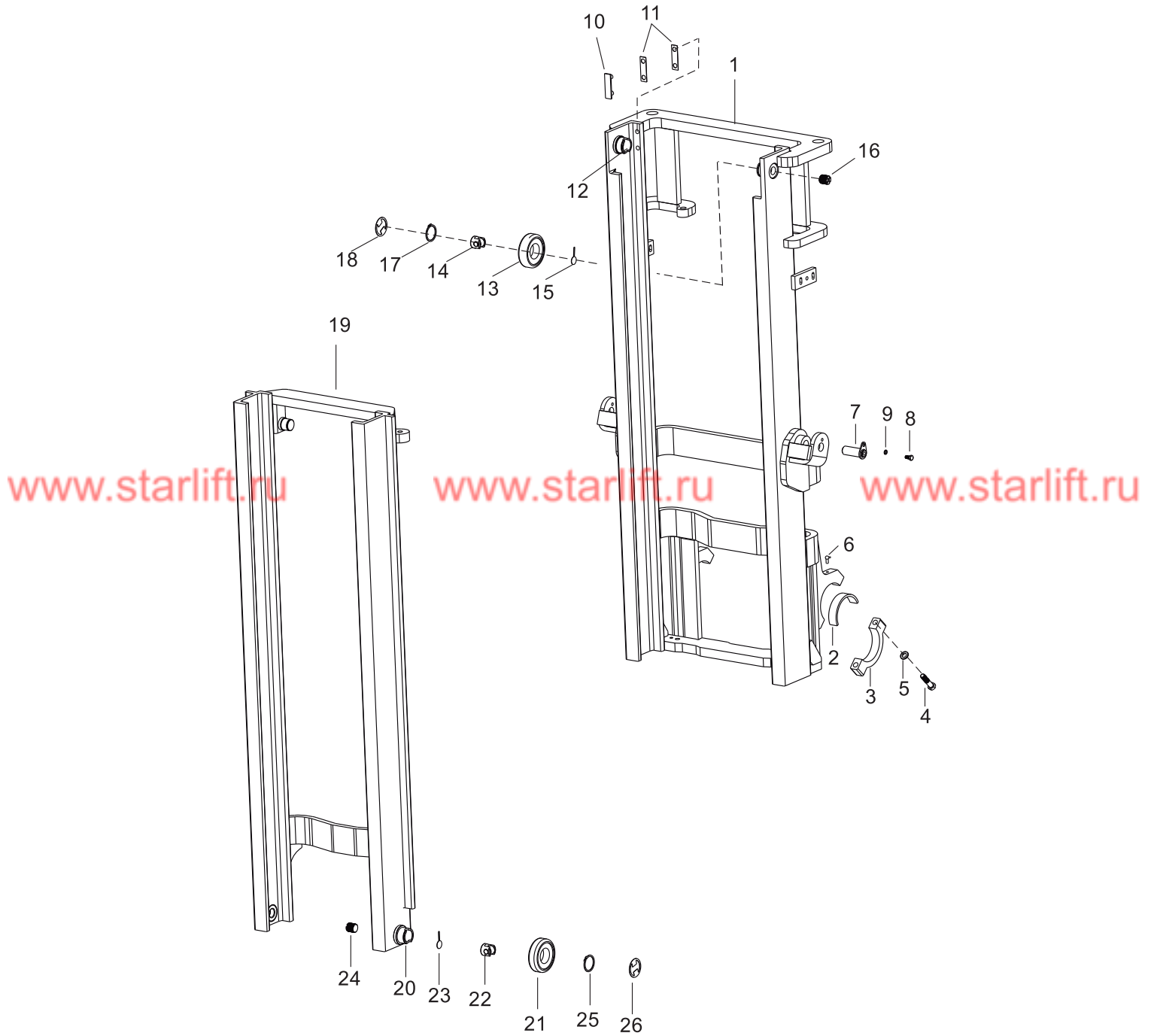

## 门架(基本型)

## Mast (Normal mast KM)

序号 Item	零件号 Part No	零部件名称 Description	数量 Q'ty	备注 Remark
1	M30A3-10000	外门架 Mast,outer	1	3t
	M20A3-10000	外门架 Mast,outer	1	2-2.5t
	M35A3-10000	外门架 Mast,outer	1	3.5t
2	M30A3-00002	轴衬 Bushing	2	
3	M30A3-00001	支座盖 Cap	2	
4	GB/T5785-1985	螺栓M16×1.5×70 Bolt	4	
5	GB/T93-1987	弹垫16 Washer,lock	4	
6	JB/TT7940.1-1995	直通式压注油杯 Oil cup	2	
7	M30A3-00100	倾斜油缸销轴 Pin axle	4	
8	GB/T5786-1986	螺栓M10×1.5×20 Bolt	4	
9	GB/T93-1987	弹垫10 Washer,lock	4	
10	M30A3-40001	限位滑块 Slipper	2	
11	M30A3-40002/3	调整垫片 Shim	2组	
12	M30A3-10002	滚轮轴 Shaft roller	2	
13	M30A3-40201	主滚轮 End Roller	2	
14	M30A3-40202	侧滚轮 Side roller	2	
15	M30A3-40204	止松片 Loose slice	2	
16	M30A3-40205	调节螺钉 Screw	2	
17	M30A3-40206	轴用挡圈 Snap,ring	2	
18	M30A3-40207	防尘片 Dust-Proof ring	2	

门架(基本型)  
Mast (Normal mast KM)

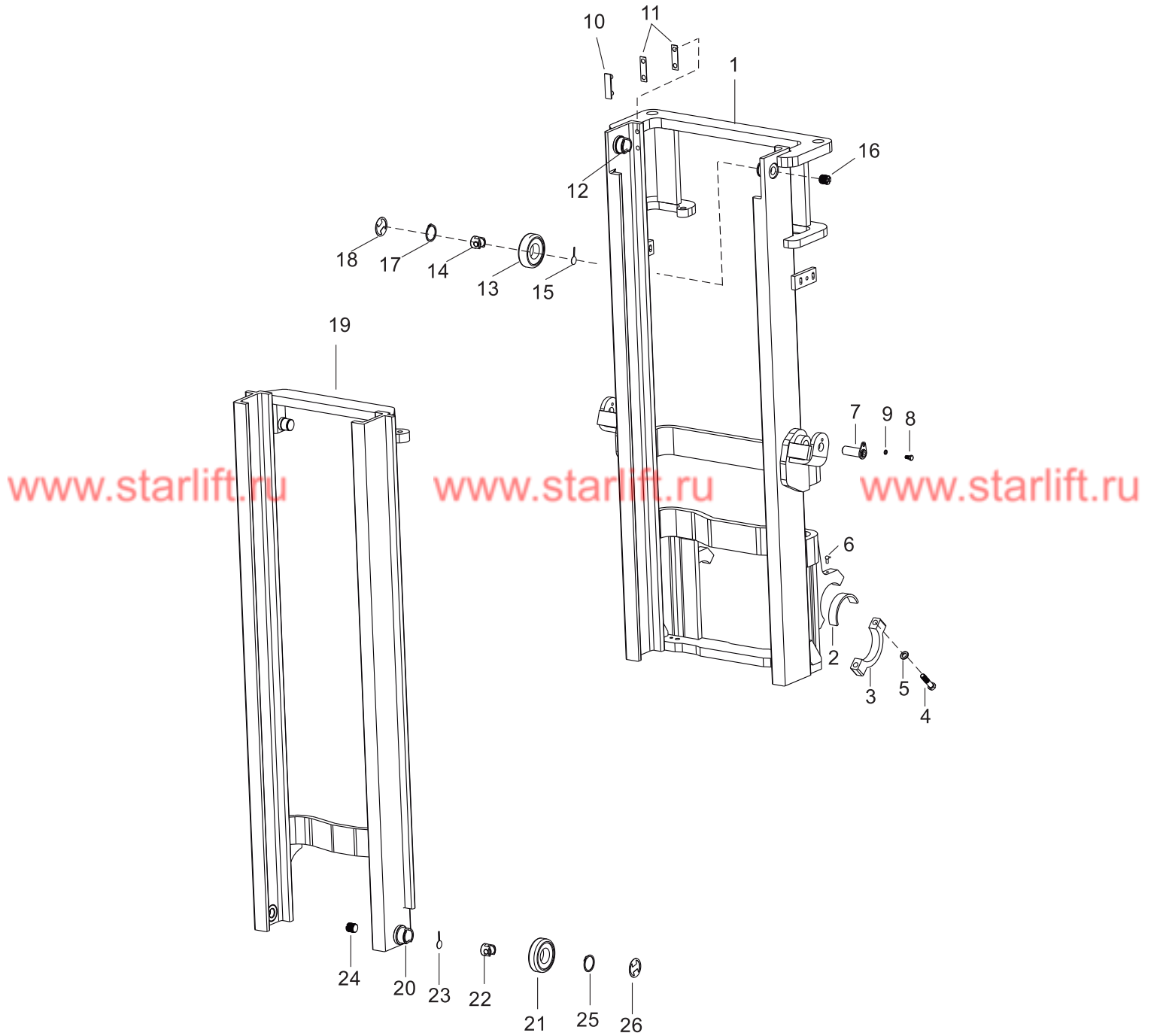

## 门架(基本型)

## Mast (Normal mast KM)

序号 Item	零件号 Part No	零部件名称 Description	数量 Q'ty	备注 Remark
19	M30A3-30000	内门架 Mast,inner	1	3t
	M20A3-30000	内门架 Mast,inner	1	2-2.5t
	M35A3-30000	内门架 Mast,inner	1	3.5t
20	M30A3-30005	滚轮轴 Shaft roller	2	
21	M30A3-40301	主滚轮 End Roller	2	
22	M30A3-40302	侧滚轮 Side roller	2	
23	M30A3-40304	止松片 Loose slice	2	
24	M30A3-40305	调节螺钉 Screw	2	
25	M30A3-40306	轴用挡圈 Snap,ring	2	
26	M30A3-40307	防尘片 Dust-Proof ring	2	

门架(二节全自由)  
Mast (Full free 2-stage mast KZM)

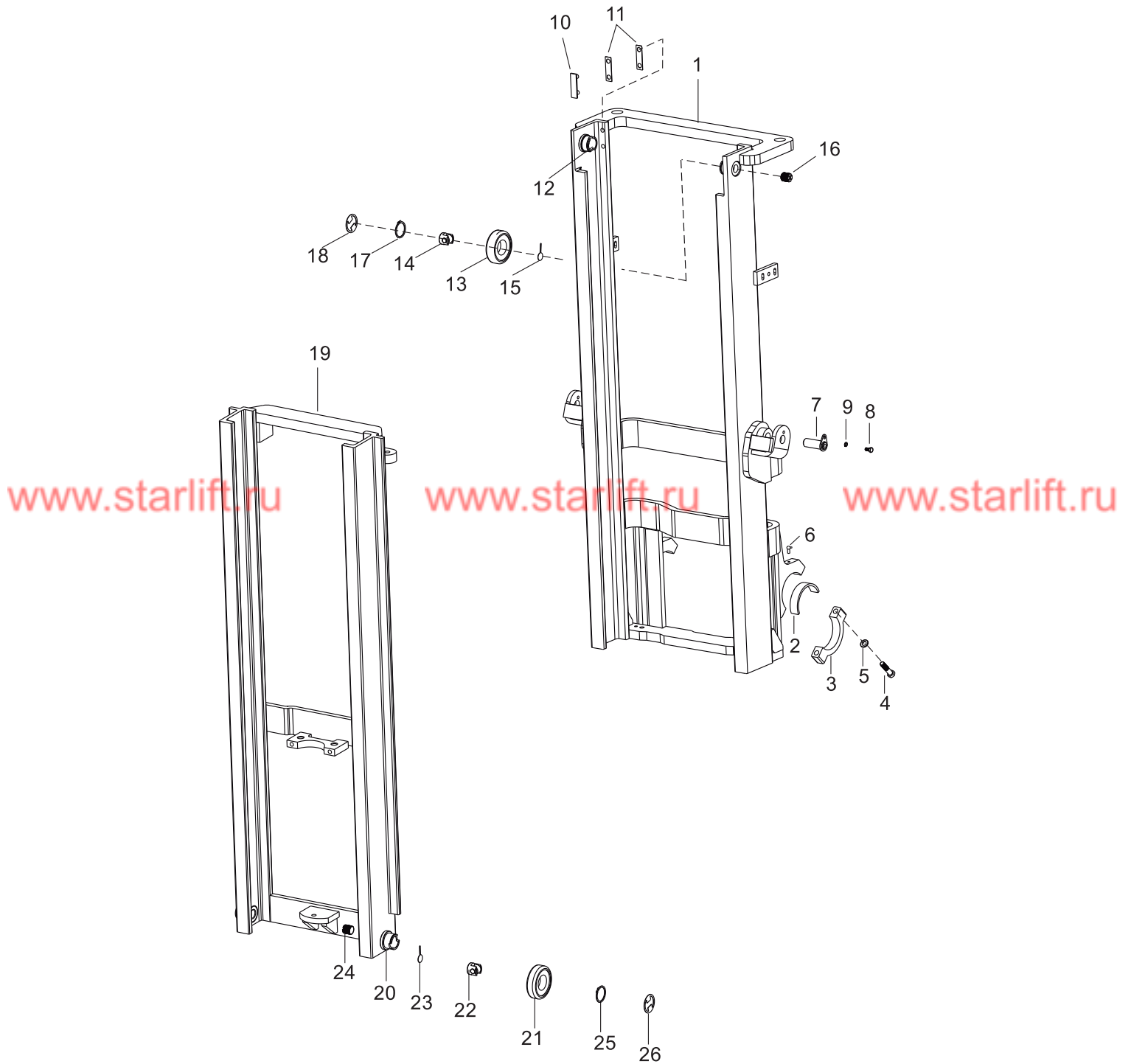

## 门架(二节全自由)

## Mast (Full free 2-stage mast KZM)

序号 Item	零件号 Part No	零部件名称 Description	数量 Q'ty	备注 Remark
1	Z30A3-10000	外门架 Mast,outer	1	3t
	Z35A3-10000	外门架 Mast,outer	1	3.5t
	Z20A3-10000	外门架 Mast,outer	1	2-2.5t
2	M30A3-00002	轴衬 Bushing	2	
3	M30A3-00001	支座盖 Cap	2	
4	GB/T5785-1985	螺栓M16×1.5×70 Bolt	4	
5	GB/T93-1987	弹垫16 Washer,lock	4	
6	JB/TT7940.1-1995	直通式压注油杯 Oil cup	2	
7	M30A3-00100	倾斜油缸销轴 Pin axle	4	
8	GB/T5786-1986	螺栓M10×1.5×20 Bolt	4	
9	GB/T93-1987	弹垫10 Washer,lock	4	
10	M30A3-40001	限位滑块 Slipper	2	
11	M30A3-40002/3	调整垫片 Shim	2组	
12	M30A3-10002	滚轮轴 Shaft roller	2	
13	M30A3-40201	主滚轮 End Roller	2	
14	M30A3-40202	侧滚轮 Side roller	2	
15	M30A3-40204	止松片 Loose slice	2	
16	M30A3-40205	调节螺钉 Screw	2	
17	M30A3-40206	轴用挡圈 Snap,ring	2	
18	M30A3-40207	防尘片 Dust-Proof ring	2	
19	Z30A3-30000	内门架 Mast,inner	1	3t

门架(二节全自由)  
Mast (Full free 2-stage mast KZM)

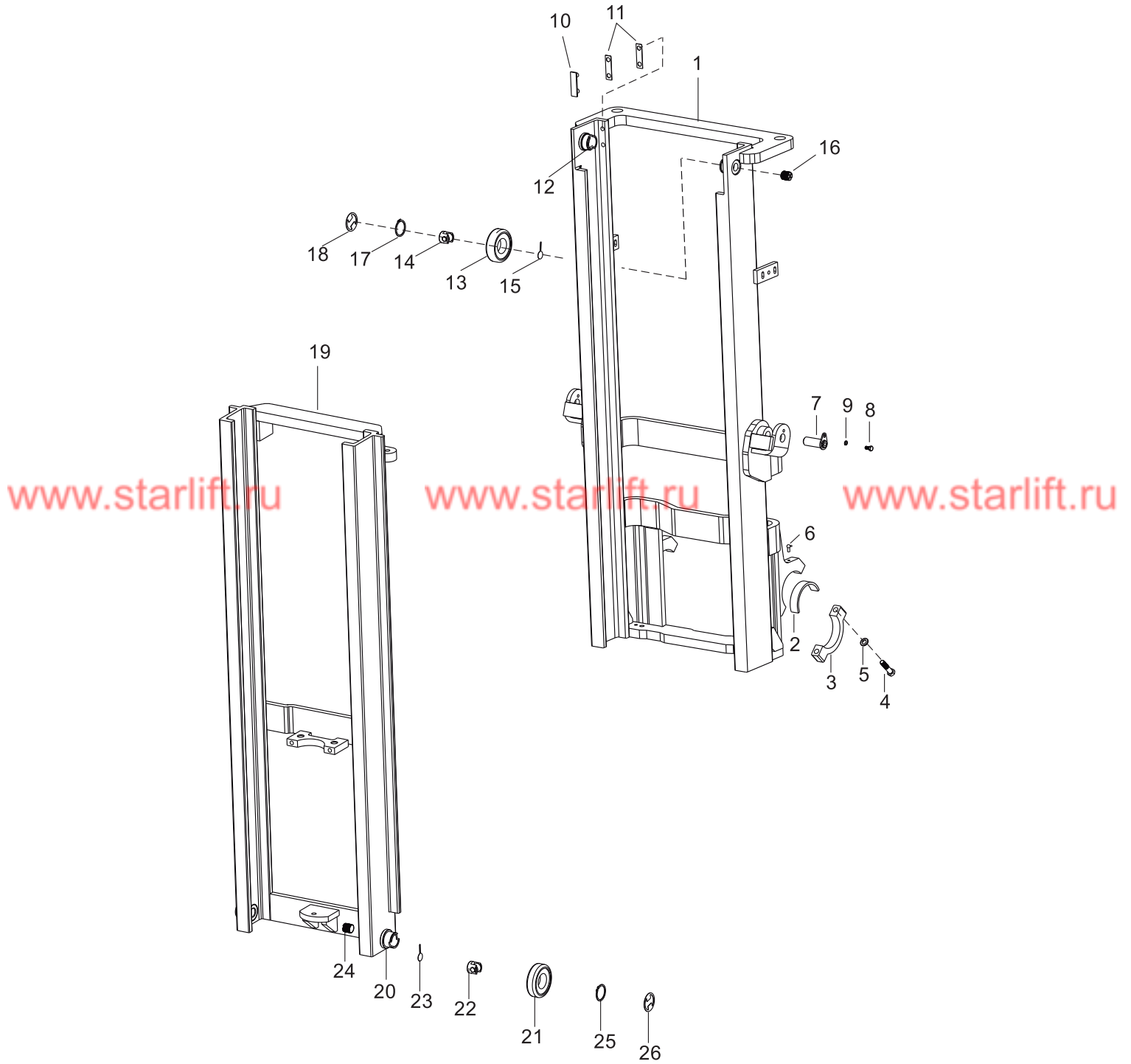



## 门架(二节全自由)

## Mast (Full free 2-stage mast KZM)

序号 Item	零件号 Part No	零部件名称 Description	数量 Q'ty	备注 Remark
	Z35A3-30000	内门架 Mast,inner	1	3.5t
	Z20A3-30000	内门架 Mast,inner	1	2-2.5t
20	M30A3-30005	滚轮轴 Shaft roller	2	
21	M30A3-40301	主滚轮 End Roller	2	
22	M30A3-40302	侧滚轮 Side roller	2	
23	M30A3-40304	止松片 Loose slice	2	
24	M30A3-40305	调节螺钉 Screw	2	
25	M30A3-40306	轴用挡圈 Snap,ring	2	
26	M30A3-40307	防尘片 Dust-Proof ring	2	

### 门架(三节全自由)

Mast (Full free 3-stage mast KZM)

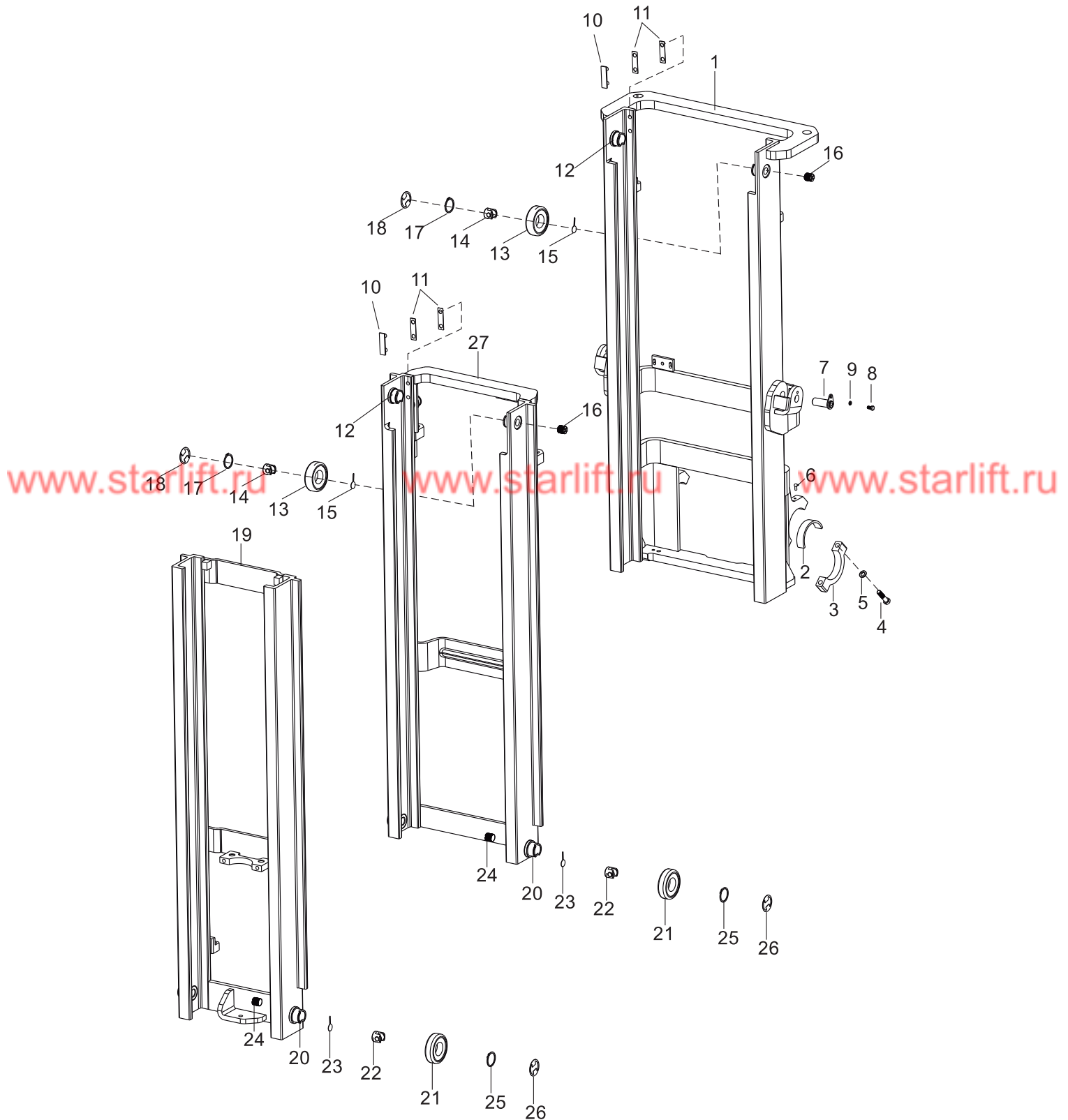

## 门架(三节全自由)

## Mast (Full free 3-stage mast KZM)

序号 Item	零件号 Part No	零部件名称 Description	数量 Q'ty	备注 Remark
1	S30C3-10000	外门架 Outer master	1	3t
	S20C3-10000	外门架 Outer master	1	2-2.5t
2	M30A3-00002	轴衬 Bushing	2	
3	M30A3-00001	支座盖 Cap	2	
4	GB/T5785-1985	螺栓M16×1.5×70 Bolt	4	
5	GB/T93-1987	弹垫16 Washer,lock	4	
6	JB/TT7940.1-1995	直通式压注油杯 Oil cup	2	
7	M30A3-00100	倾斜油缸销轴 Pin axle	4	
8	GB/T5786-1986	螺栓M10×1.5×20 Bolt	4	
9	GB/T93-1987	弹垫10 Washer,lock	4	
10	M30A3-40001	限位滑块 Slipper	4	
11	M30A3-40002/3	调整垫片 Shim	4组	
12	M30A3-10002	滚轮轴 Shaft roller	4	
13	M30A3-40201	主滚轮 End Roller	4	
14	M30A3-40202	侧滚轮 Side roller	4	
15	M30A3-40204	止松片 Loose slice	4	
16	M30A3-40205	调节螺钉 Screw	4	
17	M30A3-40206	轴用挡圈 Snap,ring	4	
18	M30A3-40207	防尘片 Dust-Proof ring	4	
19	S30C3-30000	内门架 Inner master	1	3t

### 门架(三节全自由)

Mast (Full free 3-stage mast KZM)

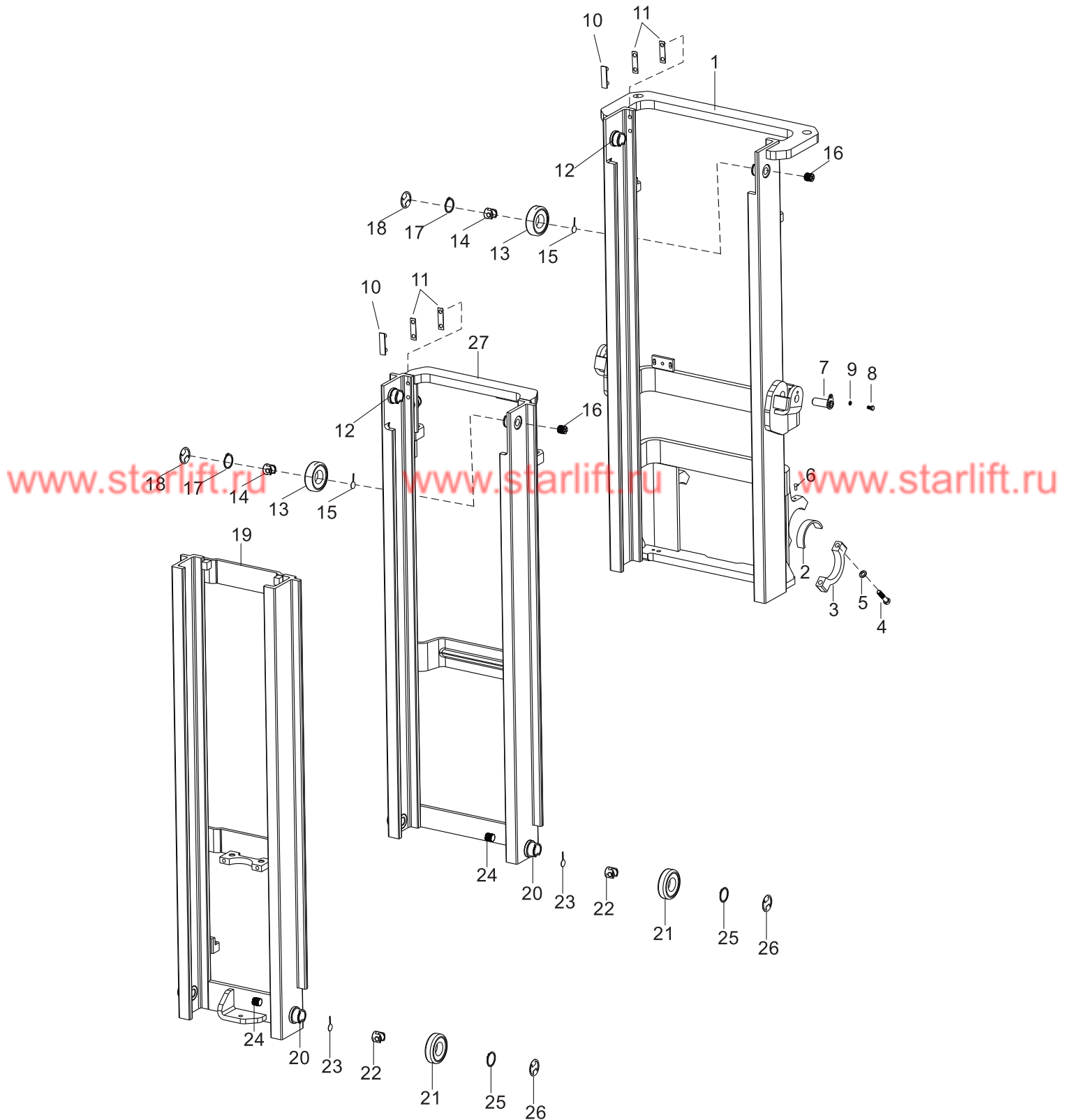

## 门架(三节全自由)

## Mast (Full free 3-stage mast KZM)

序号 Item	零件号 Part No	零部件名称 Description	数量 Q'ty	备注 Remark
	S20C3-30000	内门架 Inner master	1	2-2.5t
20	M30A3-30005	滚轮轴 Shaft roller	4	
21	M30A3-40301	主滚轮 End Roller	4	
22	M30A3-40302	侧滚轮 Side roller	4	
23	M30A3-40304	止松片 Loose slice	4	
24	M30A3-40305	调节螺钉 Screw	4	
25	M30A3-40306	轴用挡圈 Snap,ring	4	
26	M30A3-40307	防尘片 Dust-Proof ring	4	
27	S30C3-20000	中门架 Medium Master	1	3t
	S20C3-20000	中门架 Medium Master	1	2-2.5t