

起升油缸（基本型）
Lift Cylinder(Normal Mast KM)

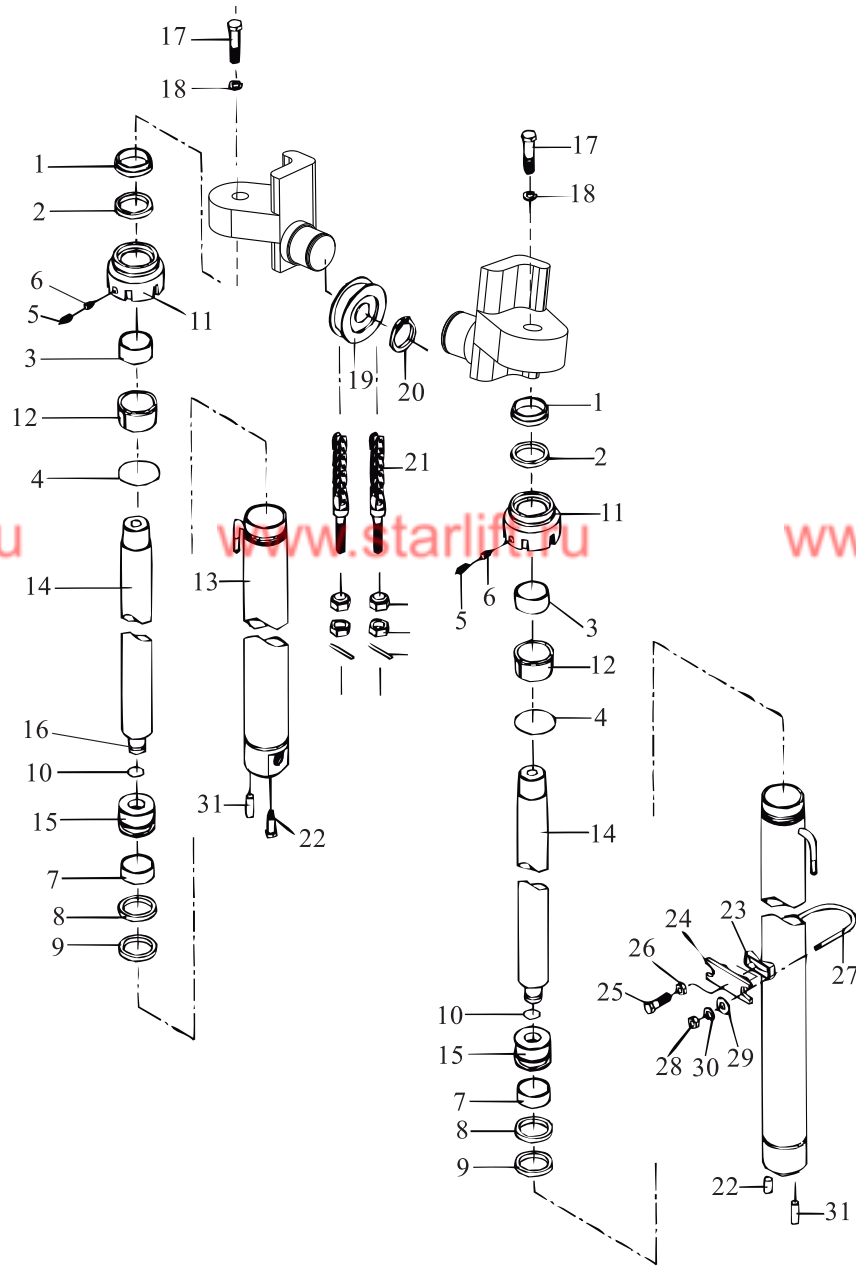

起升油缸（基本型）

Lift Cylinder(Normal Mast KM)

序号 Item	零件号 Part No	零部件名称 Description	数量 Q'ty	备注 Remark
A	A30A4-10100	起升油缸总成 Lift cylinder ass,y	1	3t
	A20A4-10100	起升油缸总成 Lift cylinder ass,y	1	2-2.5t
	A35A4-10100	起升油缸总成 Lift cylinder ass,y	1	3.5t
1	A30A4-10101	防尘圈45×57×7/10 Dust ring	2	3t
	A20A4-10101	防尘圈40×48×5/6.5 Dust ring	2	2-2.5t
	A35A4-10103	防尘圈50×62×7/10 Dust ring	2	3.5t
2	A30A4-10102	密封圈45×55×6 Ring	2	3t
	A20A4-10102	密封圈40×50×6 Ring	2	2-2.5t
	A35A4-10104	密封圈50×60×6 Ring	2	3.5t
3	A30A4-10103	钢背轴承4530 Guide bushing	2	3t
	A20A4-10103	钢背轴承4030 Guide bushing	2	2-2.5t
	A35A4-10105	钢背轴承5040 Guide bushing	2	3.5t
4	GB/T1235-76	O型密封圈68×3.1 O-ring	2	2-3t
	GB/T1235-76	O型密封圈75×3.1 O-ring	2	3.5t
5	GB/T80-1985	螺钉M8×8 Screw	4	3-3.5t
6	A30A4-10104	塞子 Plug	4	3t
	A35A4-10106	塞子6×3 Plug	4	3.5t
7	A30A4-10105	支承环56×20×2.5 Wearing	2	3t
	A20A4-10105	支承环50×20×2.5 Wearing	2	2-2.5t
	A35A4-10107	支承环60×20×2.5 Wearing	2	3.5t
8	A30A4-10106	挡片56×45×3 Ring, back up	2	3t
	A20A4-10106	挡片50×40×3 Ring, back up	2	2-2.5t
	A35A4-10108	挡片63×53×3 Ring, back up	2	3.5t

起升油缸(基本型) Lift Cylinder(Normal mast KM)

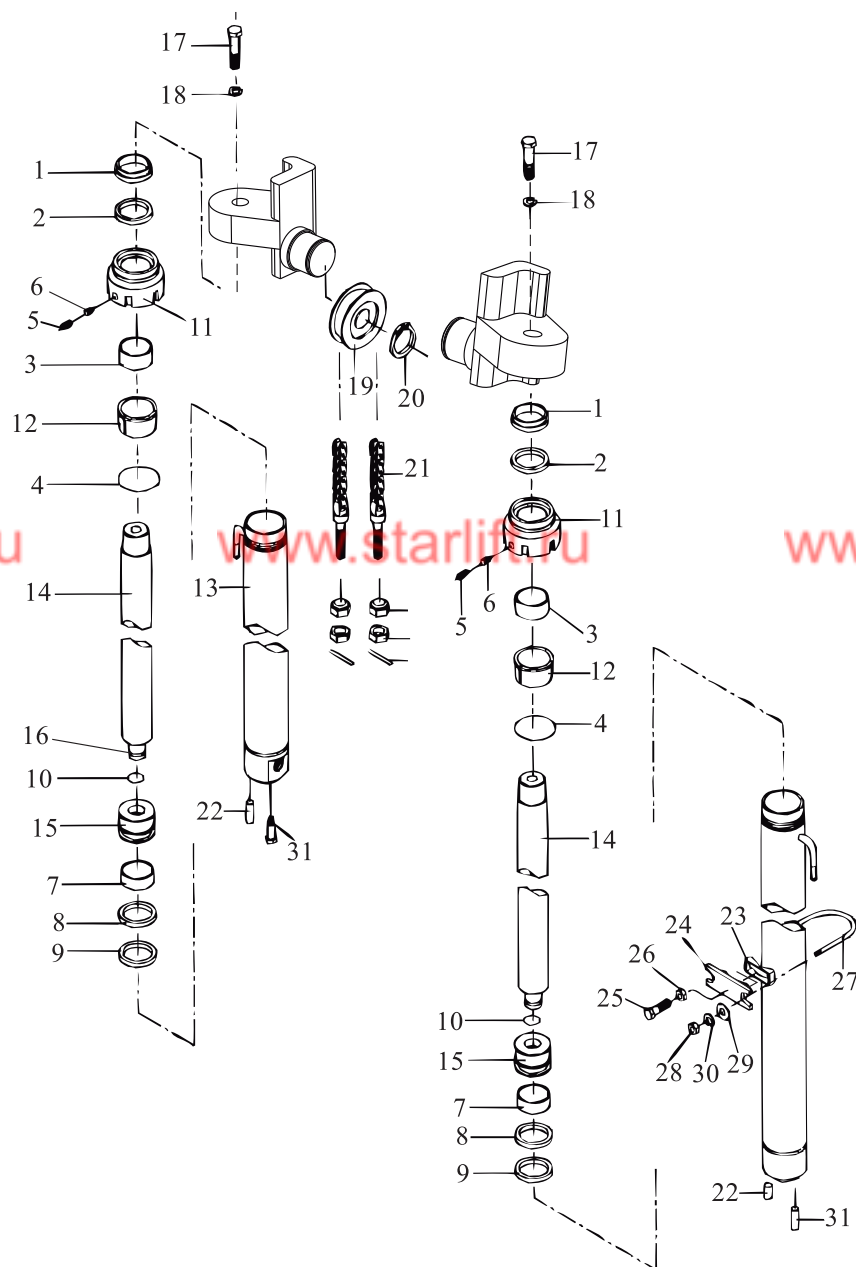

起升油缸(基本型)

Lift Cylinder(Normal mast KM)

序号 Item	零件号 Part No	零部件名称 Description	数量 Q'ty	备注 Remark
9	A30A4-10107	U型密封圈56×45×7 U-ring	2	3t
	A20A4-10107	孔用密封圈50×40×6 Ring	2	2-2.5t
	A35A4-10109	孔用密封圈63×53×6 Ring	2	3.5t
10	A30A4-10108	钢丝挡圈 Snap ring	2	2-3t
	A35A4-10110	钢丝挡圈 Snap ring	2	3.5t
11	A30A4-10109	导向套 Guide,Sleeve	2	3t
	A20A4-10109	缸盖 Cap, lift cylinder	2	2-2.5t
	A35A4-10111	缸盖 Cap, lift cylinder	2	3.5t
12	A30A4-10110	衬套 Sleeve	2	3t
	A20A4-10110	衬套 Sleeve	2	2-2.5t
	A35A4-10112	衬套 Sleeve	2	3.5t
13	A30A4-10111	缸体 Cylinder	2	3t
	A20A4-10111	缸体 Cylinder	2	2-2.5t
	A35A4-10101	缸体 Cylinder	2	3.5t
14	A30A4-10112	活塞杆 Piston rod	2	3t
	A20A4-10112	活塞杆 Piston rod	2	2-2.5t
	A35A4-10102	活塞杆 Piston rod	2	3.5t
15	A30A4-10113	活塞 Piston	2	3t
	A20A4-10113	活塞 Piston	2	2-2.5t
	A35A4-10113	活塞 Piston	2	3.5t
16	A30A4-10114	调整套 Spacer	2	3t
	A20A4-10114	调整套 Spacer	2	2-2.5t
	A35A4-10114	调整套 Spacer	2	3.5t

起升油缸(基本型)
Lift Cylinder(Normal mast KM)

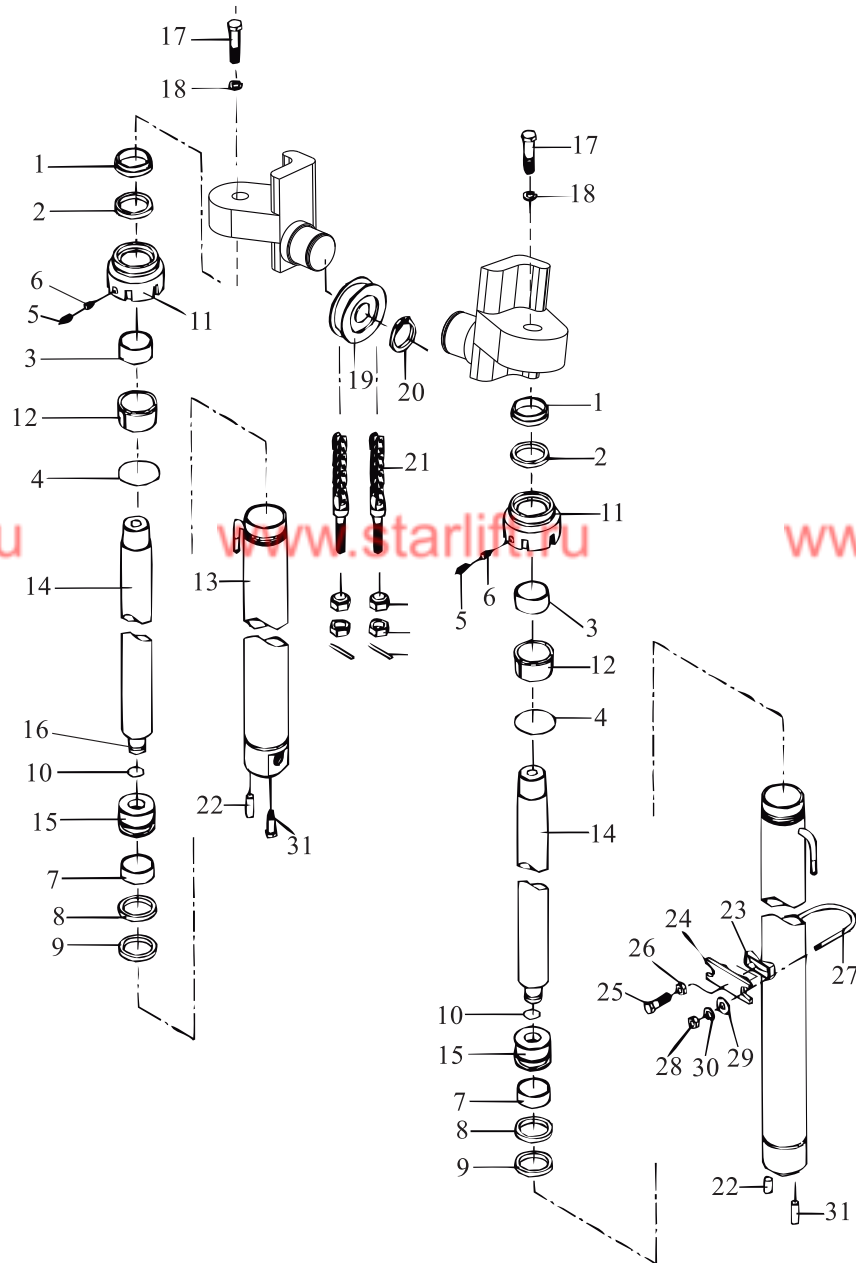

起升油缸(基本型)

Lift Cylinder(Normal mast KM)

序号 Item	零件号 Part No	零部件名称 Description	数量 Q'ty	备注 Remark
17	GB/T5786-1986	螺栓 M16×1.5×40 Bolt	2	2-3t
	GB/T5786-1986	螺栓 M20×1.5×50 Bolt	2	3.5t
18	GB/T93-1987	弹垫16 Washer,lock	2	2-3t
	GB/T93-1987	弹垫20 Washer,lock	2	3.5t
19	M30A3-80100	链轮 Sheave	2	2-3t
	M35A3-80100	链轮 Sheave	2	3.5t
20	GB/T894.1-1986	弹性挡圈40 Snap ring	2	2-3t
	GB/T894.1-1986	弹性挡圈45 Snap ring	2	3.5t
21	LH1623×N	链条总成 Chain ass'y	2	2-3t
	LH1634×N	链条总成 Chain ass'y	2	3.5t
22	GB/T119-1986	销D10×26 Pin	2	
23	M30A3-80002	调整块 Spacer	2	
24	M30A3-80003	油缸支撑块 Support	2	
25	GB/T5786-1986	螺栓M12×1.25×50 Bolt	2	
26	GB/T6171-1986	螺母M12×1.25 Nut	2	
27	M30A3-80004	U型螺栓 U-Bolt	2	3t
	M20A3-80001	U型螺栓 U-Bolt	2	2-2.5t
	M35A3-80001	U型螺栓 U-Bolt	2	3.5t
28	GB/T6173-1986	螺母M10 Nut	4	
29	GB/T97.1-1985	平垫10 Washer	4	
30	GB/T93-1987	弹垫10 Washer,lock	4	
31	M30A3-80001	台阶螺栓 Bolt	2	

前起升油缸(二节全自由)
Front Lift Cylinder (Full Free 2-Stage Mast KZM)

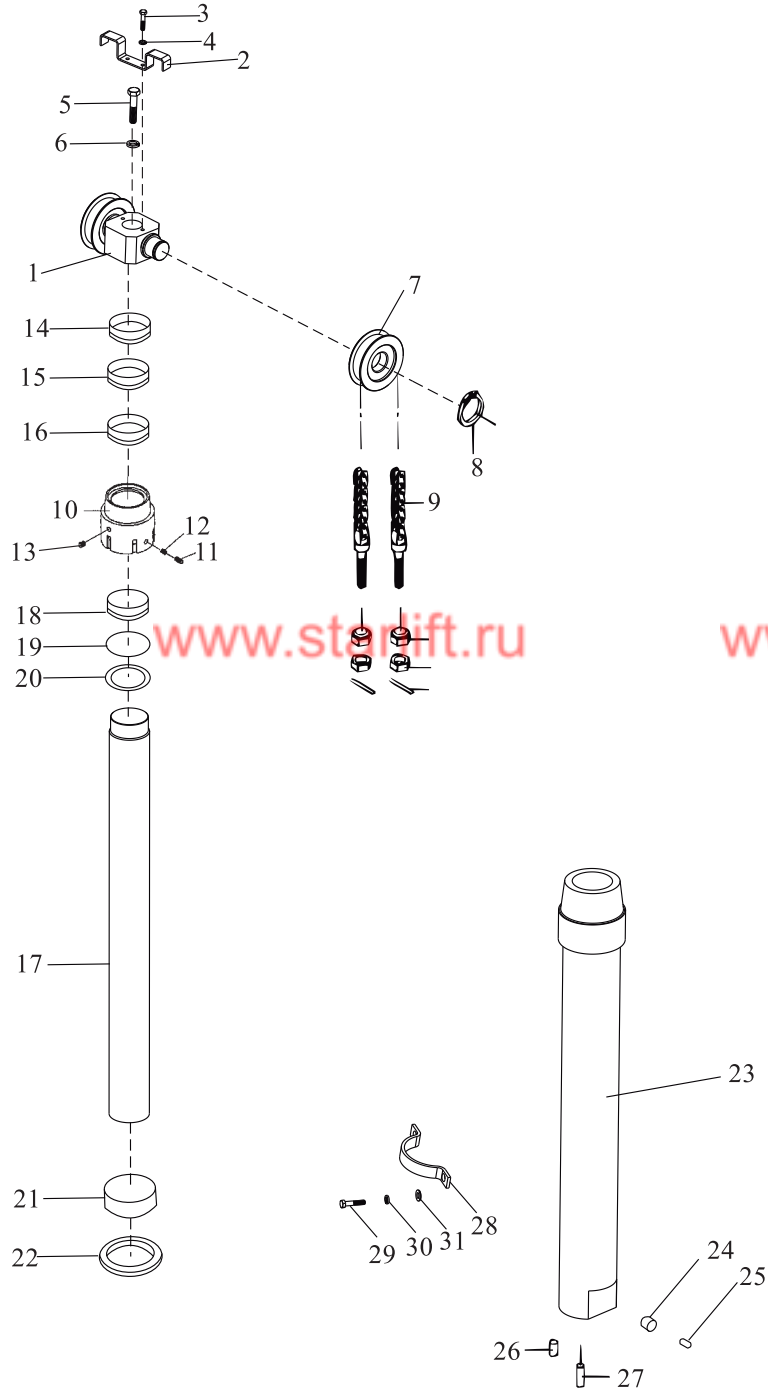

前起升油缸(二节全自由)

Front Lift Cylinder (Full Free 2-Stage Mast KZM)

序号 Item	零件号 Part No	零部件名称 Description	数量 Q'ty	备注 Remark
A	A30A4-10300	前起升油缸总成 Front lift cylinder ass'y	1	3t
	A20A4-10300	前起升油缸总成 Front lift cylinder ass'y	1	2-2.5t
	A35A4-10300	前起升油缸总成 Front lift cylinder ass'y	1	3.5t
1	Z30A3-90100	链轮支座 Sheave Seat	1	2-3t
	Z35A3-90100	链轮支座 Sheave Seat	1	3.5t
2	Z30A3-90103	链条挡板 Stopper chain	1	2-3t
	Z35A3-90002	链条挡板 Stopper chain	1	3.5t
3	GB/T93-1987	弹垫8 Washer,lock	2	
4	GB/T5783-2000	螺栓 M8×20 Bolt	2	
5	GB/T5783-2000	螺栓 M16×45 Bolt	1	
6	GB/T93-1987	弹垫16 Washer,lock	1	
7	M30A3-80100	链轮 Sheave	2	2-3t
	M35A3-80100	链轮 Sheave	2	3.5t
8	GB/T894.1-1986	弹性挡圈40 Snap ring	2	
9	LH1623×N	链条总成 Chain ass'y	2	2-3t
	LH1634×N	链条总成 Chain ass'y	2	3.5t
10	A30A4-10301	前缸盖 Cap, lift cylinder	1	3t
	A20A4-10301	前缸盖 Cap, lift cylinder	1	2-2.5t
	A35A4-10301	前缸盖 Cap, lift cylinder	1	3.5t
11	GB80-1985	螺钉M8×8 Screw	1	
12	A30A4-10302	塞子 Plug	1	

前起升油缸(二节全自由)
Front Lift Cylinder (Full Free 2-Stage Mast KZM)

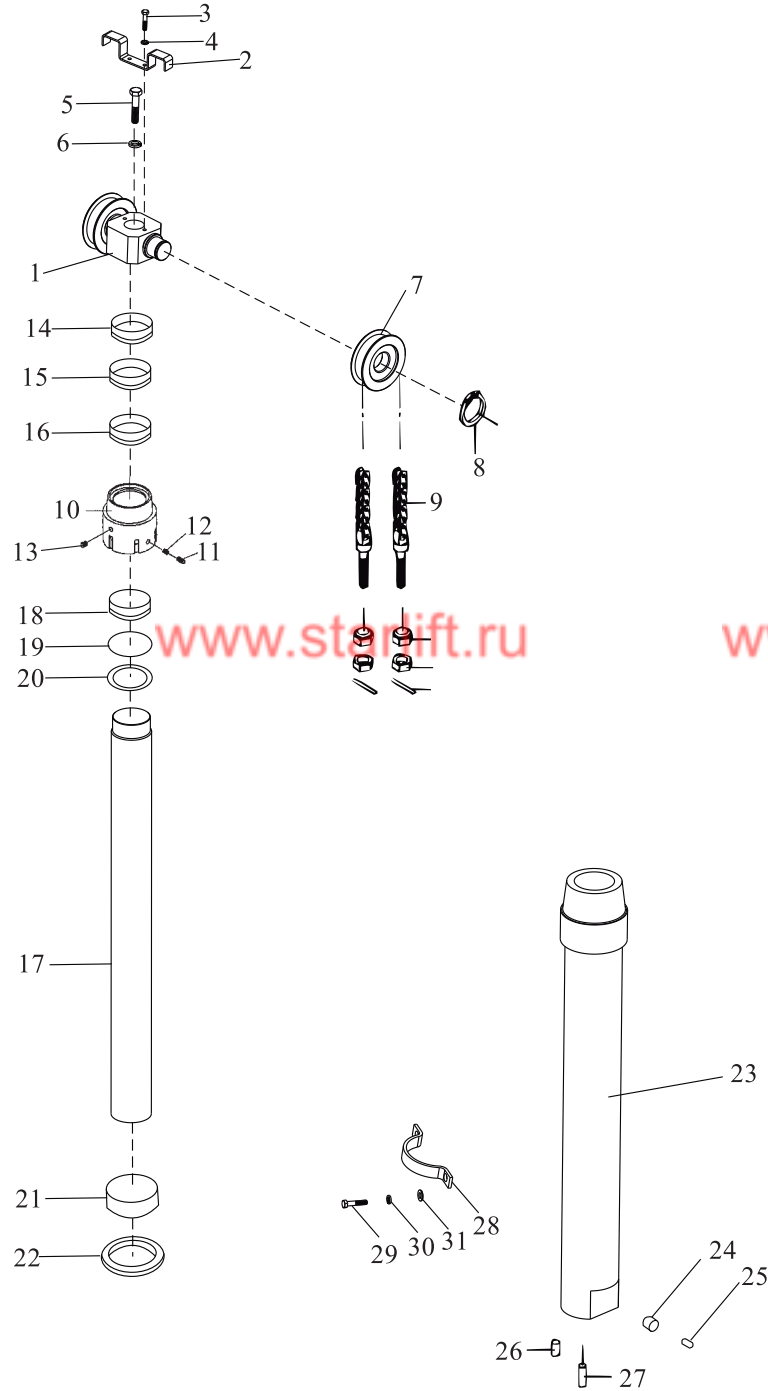

前起升油缸(二节全自由)

Front Lift Cylinder (Full Free 2-Stage Mast KZM)

序号 Item	零件号 Part No	零部件名称 Description	数量 Q'ty	备注 Remark
13	A30A4-10314	螺塞ZG1/4" Plug	1	
14	A30A4-10303	防尘圈85×99×8/11 Dust ring	1	3t
	A20A4-10303	防尘圈75×89×8/11 Dust ring	1	2-2.5t
	A35A4-10303	防尘圈95×109×8/11 Dust ring	1	3.5t
15	A30A4-10304	挡圈85×100×3 Snap ring	1	3t
	A20A4-10304	挡圈85×75×3 Snap ring	1	2-2.5t
	A35A4-10304	挡圈95×110×3 Snap ring	1	3.5t
16	A30A4-10305	Yx型密封圈85×100×9 Yx-ring	1	3t
	A20A4-10305	Yx型密封圈75×85×6 Yx-ring	1	2-2.5t
	A35A4-10305	Yx型密封圈95×110×9 Yx-ring	1	3.5t
17	A30A4-10306	柱塞杆总成 Piston rod ass'y	1	3t
	A20A4-10306	柱塞杆总成 Piston rod ass'y	1	2-2.5t
	A35A4-10306	柱塞杆总成 Piston rod ass'y	1	3.5t
18	A30A4-10307	钢背轴承8540 Guide bushing	1	3t
	A20A4-10307	钢背轴承7530 Guide bushing	1	2-2.5t
	A35A4-10307	钢背轴承9535 Guide bushing	1	3.5t
19	GB/T1235-76	O型密封圈110×3.1 O-ring	1	3t
	GB/T1235-76	O型密封圈100×3.1 O-ring	1	2-2.5t
	GB/T1235-76	O型密封圈116.8×5.33 O-ring	1	3.5t
20	A30A4-10308	挡圈110×105×1.25 Stopper	1	3t
	A20A4-10308	挡圈100×95.5×1.5 Stopper	1	2-2.5t

前起升油缸(二节全自由)

Front Lift Cylinder (Full Free 2-Stage Mast KZM)

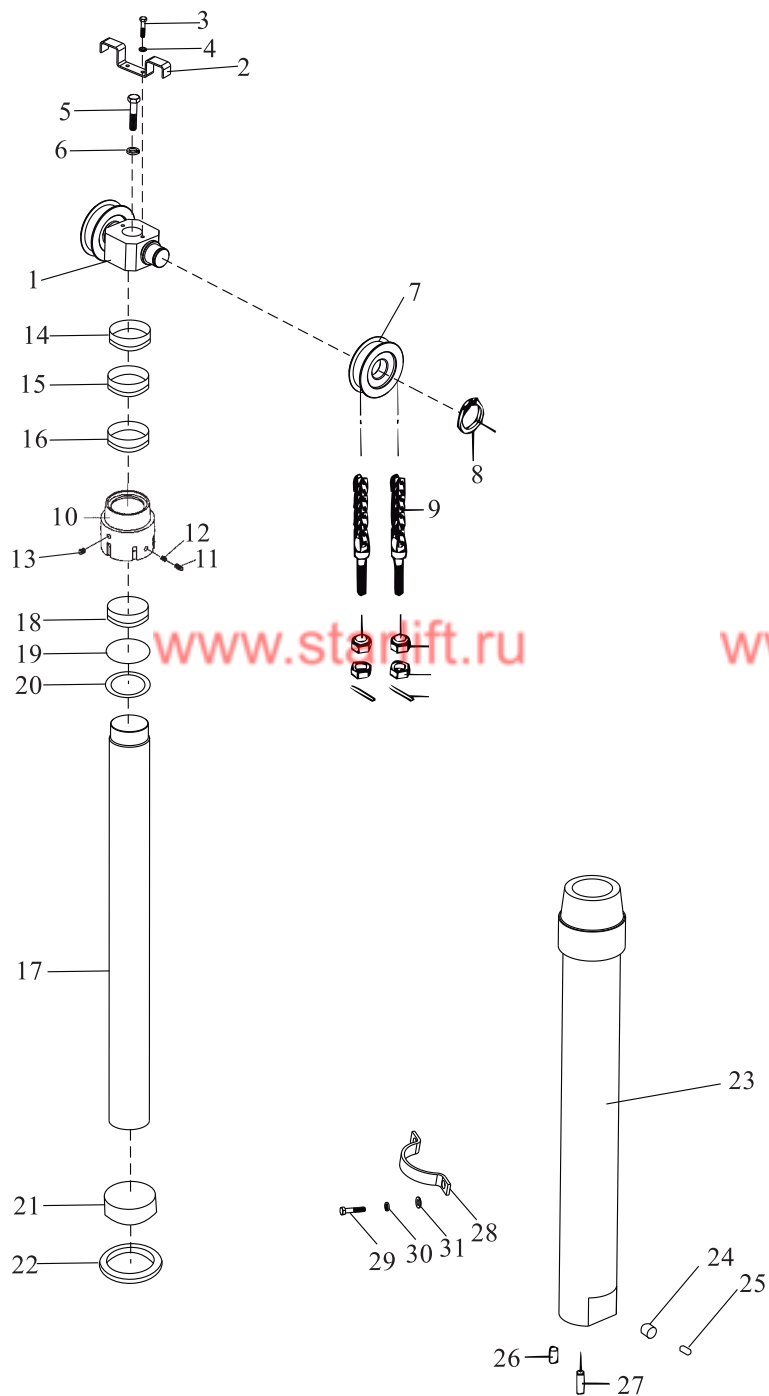

前起升油缸(二节全自由)

Front Lift Cylinder (Full Free 2-Stage Mast KZM)

序号 Item	零件号 Part No	零部件名称 Description	数量 Q'ty	备注 Remark
	A35A4-10308	挡圈125.5×116.8×1.7 Stopper	1	3.5t
21	A30A4-10309	支承环100×25×3 Backup ring	1	3t
	A20A4-10309	支承环90×3×25 Backup ring	1	2-2.5t
	A35A4-10309	支承环110×104×25 Backup ring	1	3.5t
22	A30A4-10310	密封环100×92.4×4.3 Sear ring	1	3t
	A20A4-10310	密封环90×82.4×4.3 Sear ring	1	2-2.5t
	A35A4-10310	密封环110×102.4×4.3 Sear ring	1	3.5t
23	A30A4-10311	前缸体 Cylinder	1	3t
	A30A4-10311	前缸体 Cylinder	1	2-2.5t
	A30A4-10311	前缸体 Cylinder	1	3.5t
24	A30A4-10312	滑阀 Spool	1	3t
	A20A4-10312	阀芯 Spool	1	2-2.5t
	A35A4-10312	滑阀 Spool	1	3.5t
25	A30A4-10313	弹簧 Spring	1	
26	M30A3-80001	台阶螺栓 Bolt	1	
27	GB119-1986	销D×26 Pin	1	
28	Z30A3-90001	油缸卡环 Support	1	3t
	Z20A3-90001	油缸卡环 Support	1	2-2.5t
	Z35A3-90001	油缸卡环 Support	1	3.5t
29	GB/T5783-2000	螺栓 M14×30 Bolt	2	
30	GB/T93-1987	弹垫14 Washer,lock	2	
31	GB/T848-1985	平垫14 Washer	2	

前起升油缸(三节全自由) Front Lift Cylinder (Full Free 3-Stage Mast KZM)

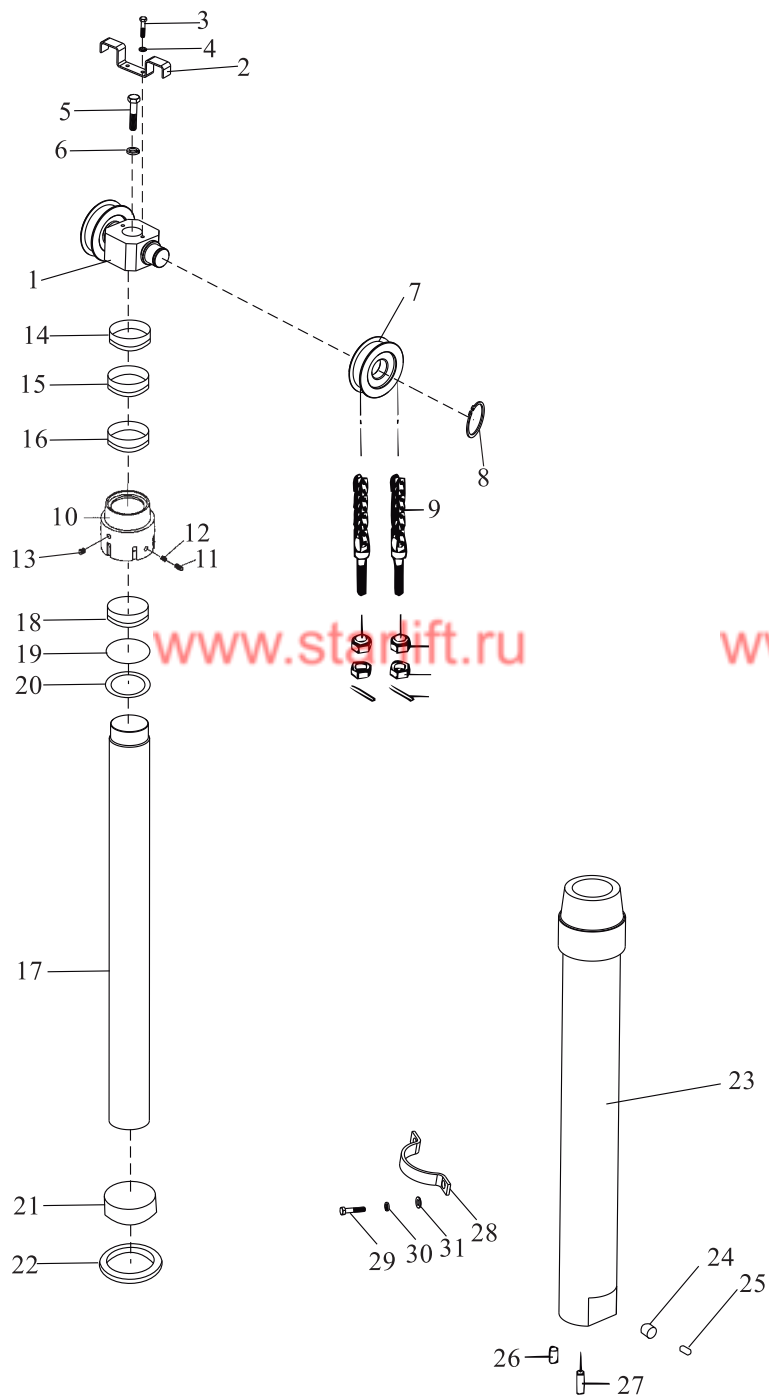

前起升油缸(三节全自由)

Front Lift Cylinder (Full Free 3-Stage Mast KZM)

序号 Item	零件号 Part No	零部件名称 Description	数量 Q'ty	备注 Remark
A	A30A4-10500	前起升油缸总成 Front lift cylinder ass'y	1	3t
	A20A4-10500	前起升油缸总成 Front lift cylinder ass'y	1	2-2.5t
1	Z30A3-90100	链轮支座 Sheave Seat	1	
2	Z30A3-90103	链条挡板 Stopper chain	1	
3	GB/T93-1987	弹垫8 Washer,lock	2	
4	GB/T5783-2000	螺栓 M8×20 Bolt	2	
5	GB/T5783-2000	螺栓 M16×45 Bolt	1	
6	GB/T93-1987	弹垫16 Washer,lock	1	
7	M30A3-80100	链轮 Sheave	2	
8	GB/T894.1-1986	弹性挡圈40 Snap ring	2	
9	LH1623×N	链条总成 Chain ass'y	2	
10	A30A4-10301	前缸盖 Cap, lift cylinder	1	3t
	A20A4-10301	前缸盖 Cap, lift cylinder	1	2-2.5t
11	GB80-1985	螺钉M8×8 Screw	1	
12	A30A4-10302	塞子 Plug	1	
13	A30A4-10314	螺塞ZG1/4" Plug	1	
14	A30A4-10303	防尘圈85×99×8/11 Dust ring	1	3t
	A20A4-10303	防尘圈75×89×8/11 Dust ring	1	2-2.5t
15	A30A4-10304	挡圈85×100×3 Snap ring	1	3t
	A20A4-10304	挡圈85×75×3 Snap ring	1	2-2.5t
16	A30A4-10305	Yx型密封圈85×100×9 Yx-ring	1	3t
	A20A4-10305	Yx型密封圈75×85×6 Yx-ring	1	2-2.5t
17	A30A4-10501	柱塞杆总成 Piston rod ass'y	1	3t

前起升油缸(三节全自由)

Front Lift Cylinder (Full Free 3-Stage Mast KZM)

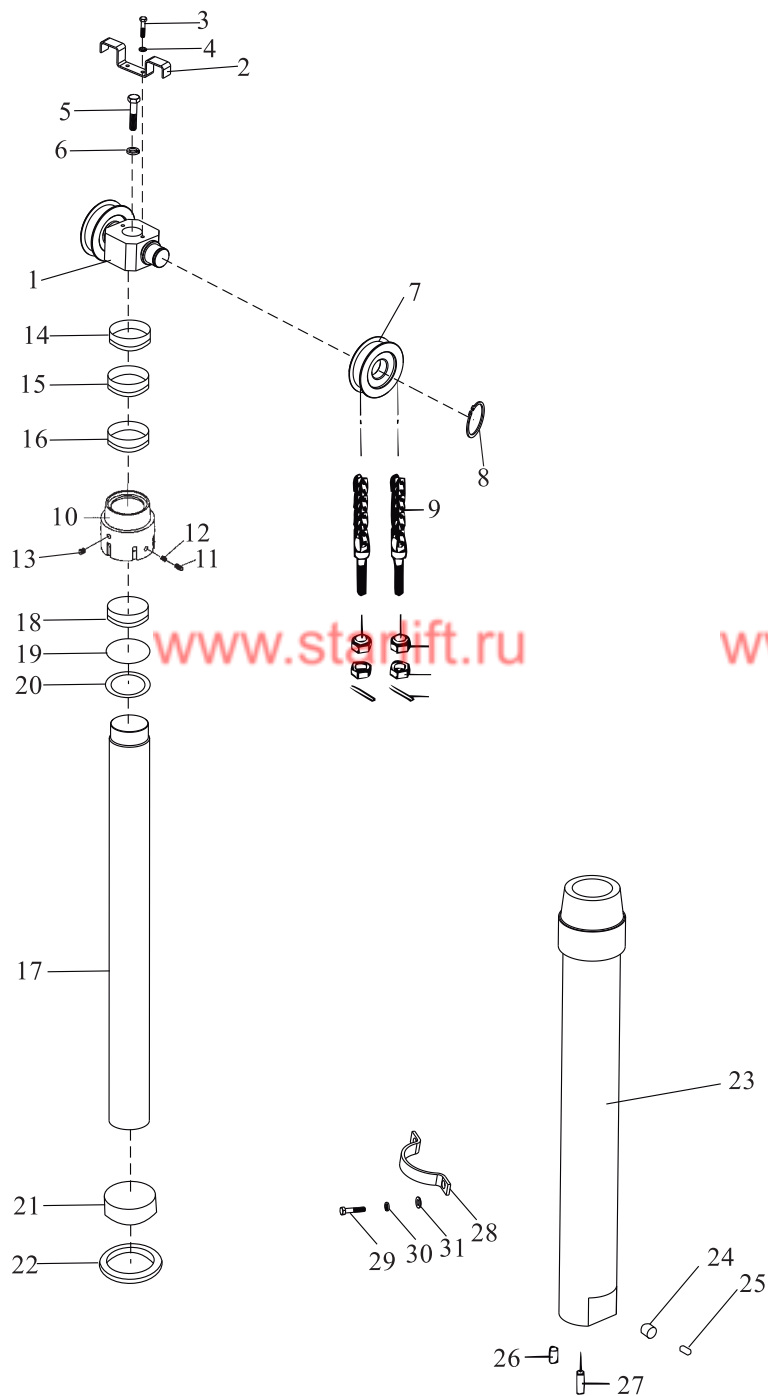

前起升油缸(三节全自由)

Front Lift Cylinder (Full Free 3-Stage Mast KZM)

序号 Item	零件号 Part No	零部件名称 Description	数量 Q'ty	备注 Remark
	A20A4-10501	柱塞杆总成 Piston rod ass'y	1	2-2.5t
18	A30A4-10307	钢背轴承8540 Guide bushing	1	3t
	A20A4-10307	钢背轴承7530 Guide bushing	1	2-2.5t
19	GB/T1235-76	O型密封圈110×3.1 O-ring	1	
20	A30A4-10308	挡圈110×105×1.25 Stopper	1	3t
	A20A4-10308	挡圈100×95.5×1.5 Stopper	1	2-2.5t
21	A30A4-10309	支承环100×25×3 Backup ring	1	3t
	A20A4-10309	支承环90×3×25 Backup ring	1	2-2.5t
22	A30A4-10310	密封环100×92.4×4.3 Sear ring	1	3t
	A20A4-10310	密封环90×82.4×4.3 Sear ring	1	2-2.5t
23	A30A4-10502	缸体 Cylinder	1	3t
	A20A4-10502	缸体 Cylinder	1	2-2.5t
24	A30A4-10312	滑阀 Spool	1	3t
	A20A4-10312	滑阀 Spool	1	2-2.5t
25	A30A4-10313	弹簧 Spring	1	3t
	A20A4-10313	弹簧 Spring	1	2-2.5t
26	GB/T5783-2000	螺栓 M12×1.25×35 Bolt	1	
27	GB119-1986	销D10×26 Pin	1	
28	Z30A3-90001	油缸卡环 Support	1	3t
	Z20A3-90001	油缸卡环 Support	1	2-2.5t
29	GB/T5783-2000	螺栓 M14×30 Bolt	2	
30	GB/T93-1987	弹垫14 Washer,lock	2	
31	GB/T848-1985	平垫14 Washer	2	

后起升油缸(二节全自由)

Rear Lift Cylinder (Full Free 2-Stage Mast KZM)

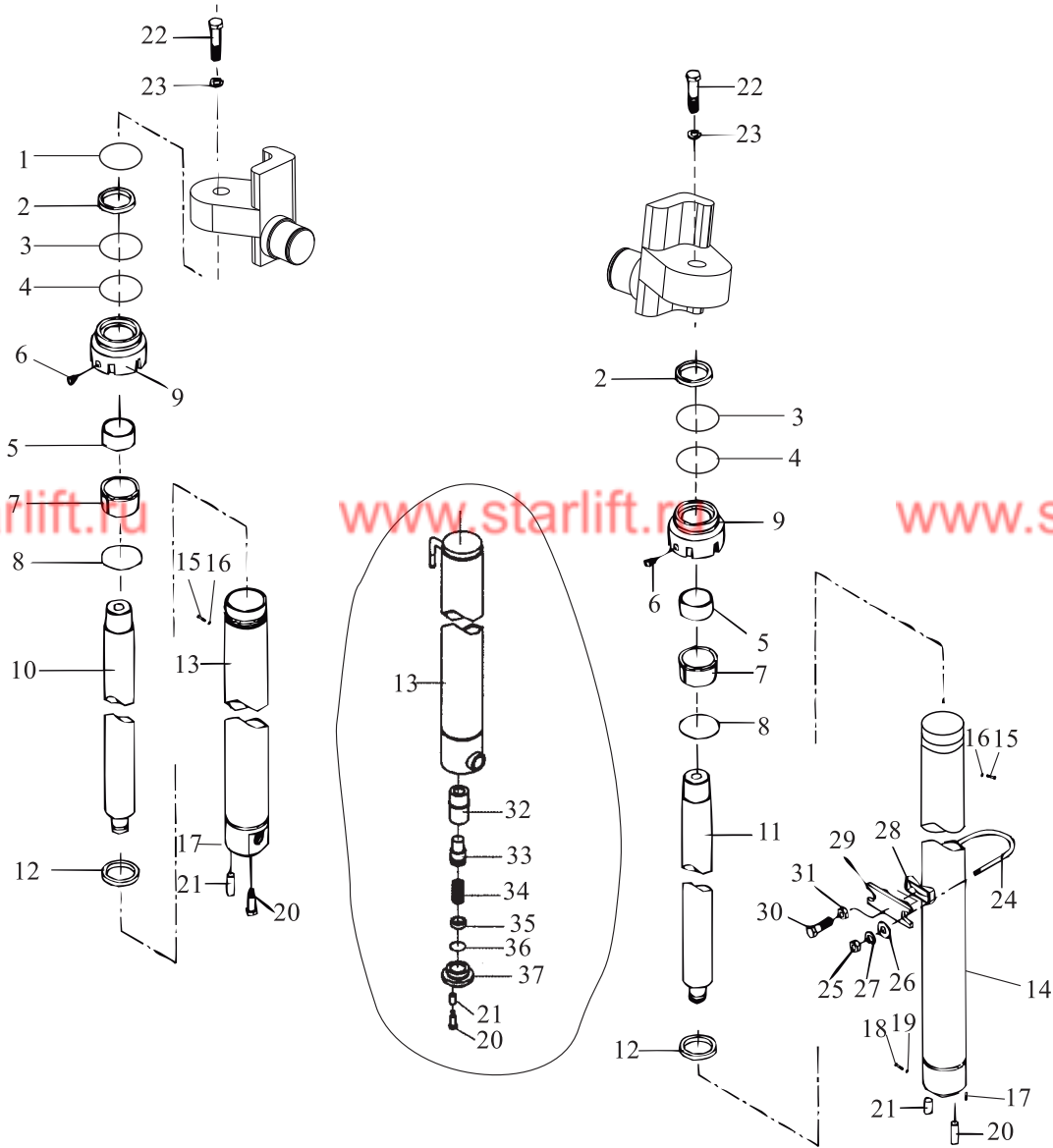

后起升油缸(二节全自由)

Rear Lift Cylinder (Full Free 2-Stage Mast KZM)

序号 Item	零件号 Part No	零部件名称 Description	数量 Q'ty	备注 Remark
A	A30A4-10400	后起升油缸总成 Rear lift cylinder ass'y	1	3t
	A20A4-10400	后起升油缸总成 Rear lift cylinder ass'y	1	2-2.5t
	A35A4-10400	后起升油缸总成 Rear lift cylinder ass'y	1	3.5t
1	GB/T1235-76	O型密封圈26×2.4 O-ring	1	
2	A30A4-10401	防尘圈40×52×7/10 Dust ring	2	3t
	A20A4-10401	防尘圈35×47×7/10 Dust ring	2	2-2.5t
	A35A4-10401	防尘圈45×57×7/10 Dust ring	2	3.5t
3	A30A4-10402	挡片50×40×3 Ring, back up	2	3t
	A20A4-10402	挡片35×45×3 Ring, back up	2	2-2.5t
	A35A4-10402	挡片45×55×3 Ring, back up	2	3.5t
4	A30A4-10403	轴用密封圈40×50×6 Ring	2	3t
	A20A4-10403	轴用密封圈35×45×6 Ring	2	2-2.5t
	A35A4-10403	U型密封圈45×55×6 U-ring	2	3.5t
5	A30A4-10404	钢背轴承4030 Guide bushing	2	2-3t
	A35A4-10404	钢背轴承4530 Guide bushing	2	3.5t
6	A30A4-10405	螺塞 Plug	4	
7	GB1235-76	O型密封圈 O-ring	2	3t
	GB1235-76	O型密封圈60×3.1 O-ring	2	2-2.5t
	GB1235-76	O型密封圈68×3.1 O-ring	2	3.5t
8	A30A4-10406	挡片 Ring, back up	2	3t
	A20A4-10406	挡片60×55×1.6 Ring, back up	2	2-2.5t
	A35A4-10406	挡片62.8×68×1.6 Ring, back up	2	3.5t
9	A30A4-10407	缸盖 Cap, lift cylinder	2	3t

后起升油缸(二节全自由)

Rear Lift Cylinder (Full Free 2-Stage Mast KZM)

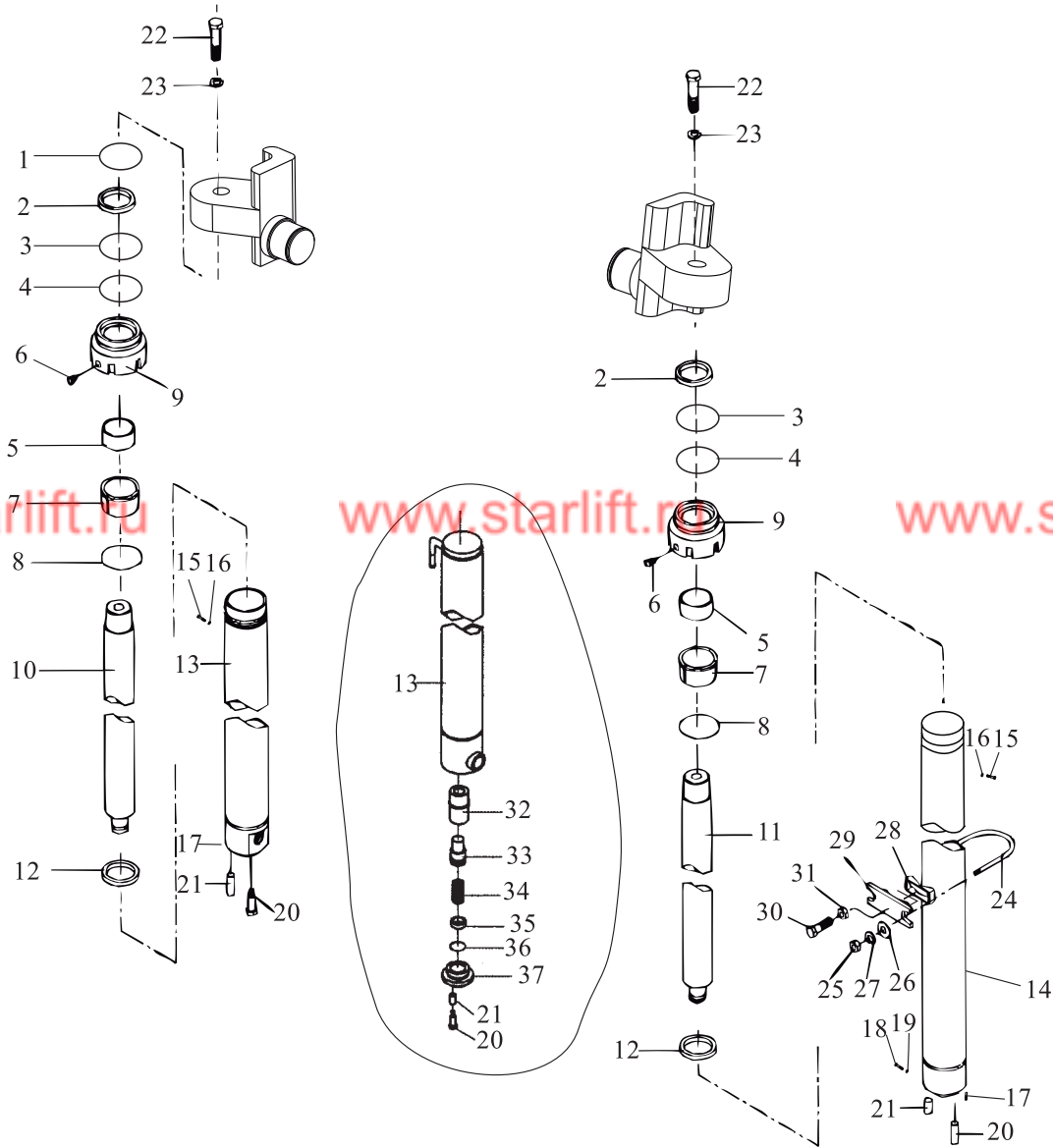

后起升油缸(二节全自由)

Rear Lift Cylinder (Full Free 2-Stage Mast KZM)

序号 Item	零件号 Part No	零部件名称 Description	数量 Q'ty	备注 Remark
	A20A4-10407	缸盖 Cap, lift cylinder	2	2-2.5t
	A35A4-10407	导向套 Guide,sleeve	2	3.5t
10	A30A4-10408	右活塞杆 Piston rod R.H.	1	3t
	A20A4-10408	右活塞杆 Piston rod R.H.	1	2-2.5t
	A35A4-10408	右活塞杆 Piston rod R.H.	1	3.5t
11	A30A4-10409	左活塞杆 Piston rod L.H.	1	3t
	A20A4-10409	左活塞杆 Piston rod L.H.	1	2-2.5t
	A35A4-10409	左活塞杆 Piston rod L.H.	1	3.5t
12	A30A4-10410	支承环50×20×2.5 Backup ring	2	2-3t
	A35A4-10410	支承环 Backup ring	2	3.5t
13	A30A4-10411	右缸体 Cylinder R.H.	1	3t
	A20A4-10411	右缸体 Cylinder R.H.	1	2-2.5t
	A35A4-10411	右缸体 Cylinder R.H.	1	3.5t
14	A30A4-10412	左缸体 Cylinder L.H.	1	3t
	A20A4-10412	左缸体 Cylinder L.H.	1	2-2.5t
	A35A4-10412	左缸体 Cylinder L.H.	1	3.5t
15	GB/T80-1985	螺钉M6×10 Screw	2	3t
	GB/T80-1985	螺钉M6×8 Screw	2	2-2.5t
	GB/T80-1985	螺钉M8×8 Screw	2	3.5t
16	A30A4-10413	塞子 Plug	2	
17	GB/T119-86	销D10×25 Pin	2	
18	A30A4-10414	阀芯 Spool	1	3t
	A20A4-10414	阀芯 Spool	1	2-2.5t

后起升油缸(二节全自由)

Rear Lift Cylinder (Full Free 2-Stage Mast KZM)

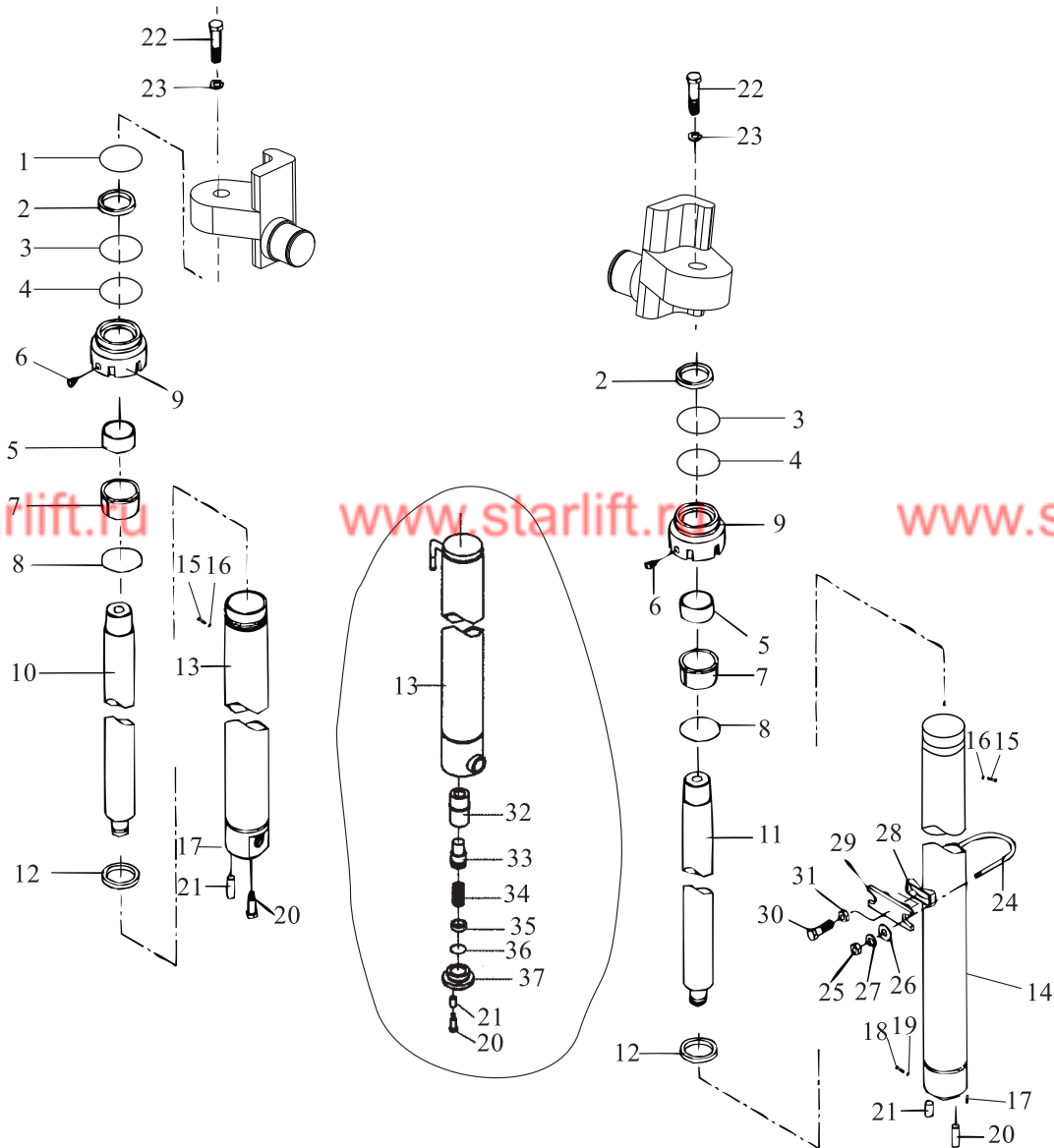

后起升油缸(二节全自由)

Rear Lift Cylinder (Full Free 2-Stage Mast KZM)

序号 Item	零件号 Part No	零部件名称 Description	数量 Q'ty	备注 Remark
	A35A4-10414	阀芯 Spool	1	3.5t
19	A30A4-10415	弹簧 Spring	1	3t
	A20A4-10415	弹簧 Spring	1	2-2.5t
	A35A4-10415	弹簧 Spring	1	3.5t
20	M30A3-80001	台阶螺栓 Bolt	2	
21	GB/T119-1986	销D10×26 Pin	2	
22	GB/T5786-2000	螺栓 M16×1.5×40 Bolt	2	
23	GB/T93-1987	弹垫16 Washer,lock	2	
24	M30A3-80004	U型螺栓 U-Bolt	2	2-3t
	M35A3-80001	U型螺栓 U-Bolt	2	3.5t
25	GB/T6173-2000	螺母M10×1.25 Nut	4	
26	GB/T97.1-1985	平垫10 Washer	4	
27	GB/T93-1987	弹垫10 Washer,lock	4	
28	M30A3-80002	调整块 Spacer	2	
29	M30A3-80003	油缸支撑块 Support	2	
30	GB/T5786-2000	螺栓M12×1.25×50 Bolt	2	
31	GB/T6171-1986	螺母M12×1.25 Nut	2	
32	A35A4-10416	阀套 Sleeve	1	3.5t
33	A35A4-10417	阀芯 Spool	1	3.5t
34	A35A4-10418	弹簧 Spring	1	3.5t
35	A35A4-10419	弹簧座 Seat, spring	1	3.5t
36	GB/T1235-76	O型密封圈40×3.5 O-ring	1	3.5t
37	A35A4-10420	底座 Seat, valve	1	3.5t

后起升油缸(三节全自由)

Rear Lift Cylinder (Full Free 3-Stage Mast KZM)

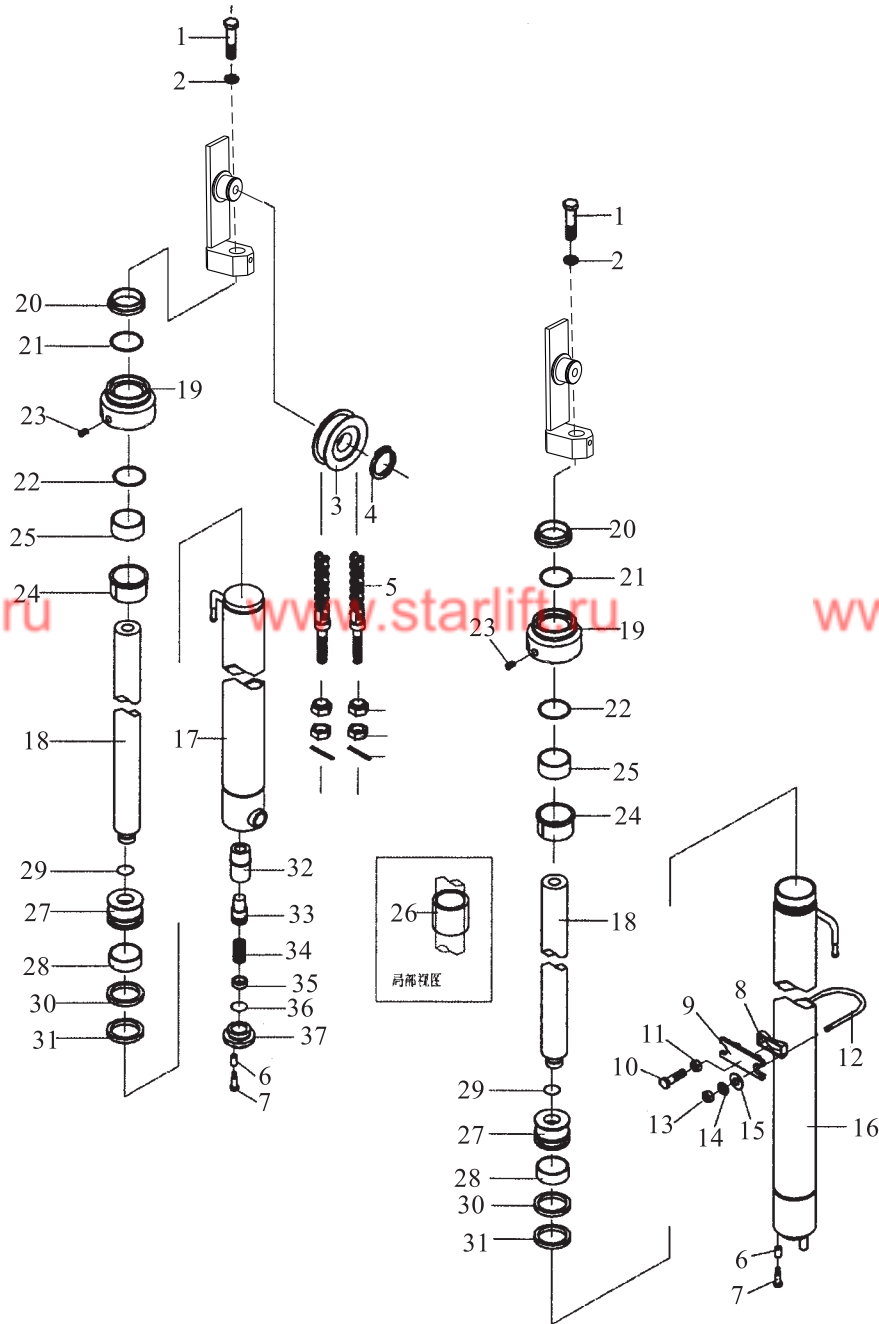

后起升油缸(三节全自由)

Rear Lift Cylinder (Full Free 3-Stage Mast KZM)

序号 Item	零件号 Part No	零部件名称 Description	数量 Q'ty	备注 Remark
A	A30A4-10600	后起升油缸总成 Raer lift cylinder ass'y	1	3t
	A20A4-10600	后起升油缸总成 Raer lift cylinder ass'y	1	2-2.5t
1	GB/T5786-2000	螺栓 M10×1.5×30 Bolt	2	
2	GB/T93-1987	弹垫10 Washer,lock	2	
3	S30C3-80200	链轮 Sheave	2	
4	GB/T894.1-1986	弹性挡圈40 Snap ring	2	
5	LH1623×N	链条总成 Chain ass'y	2	
6	GB/T119-1986	销D10×26 Pin	2	
7	M30A3-80001	台阶螺栓 Bolt	2	
8	M30A3-80002	调整块 Spacer	2	
9	M30A3-80003	油缸支撑块 Support	2	
10	GB/T5786-2000	螺栓M12×1.25×50 Bolt	2	
11	GB/T6171-1986	螺母M12×1.25 Nut	2	
12	M30A3-80004	U型螺栓 U-Bolt	2	3t
	M20A3-80001	U型螺栓 U-Bolt	2	2-2.5t
13	GB/T6173-2000	螺母M10×1.25 Nut	4	
14	GB/T97.1-1985	平垫10 Washer	4	
15	GB/T93-1987	弹垫10 Washer,lock	4	
16	A30A4-10601	左缸体 Cylinder L.H.	1	3t
	A20A4-10601	左缸体 Cylinder L.H.	1	2-2.5t

后起升油缸(三节全自由)

Rear Lift Cylinder (Full Free 3-Stage Mast KZM)

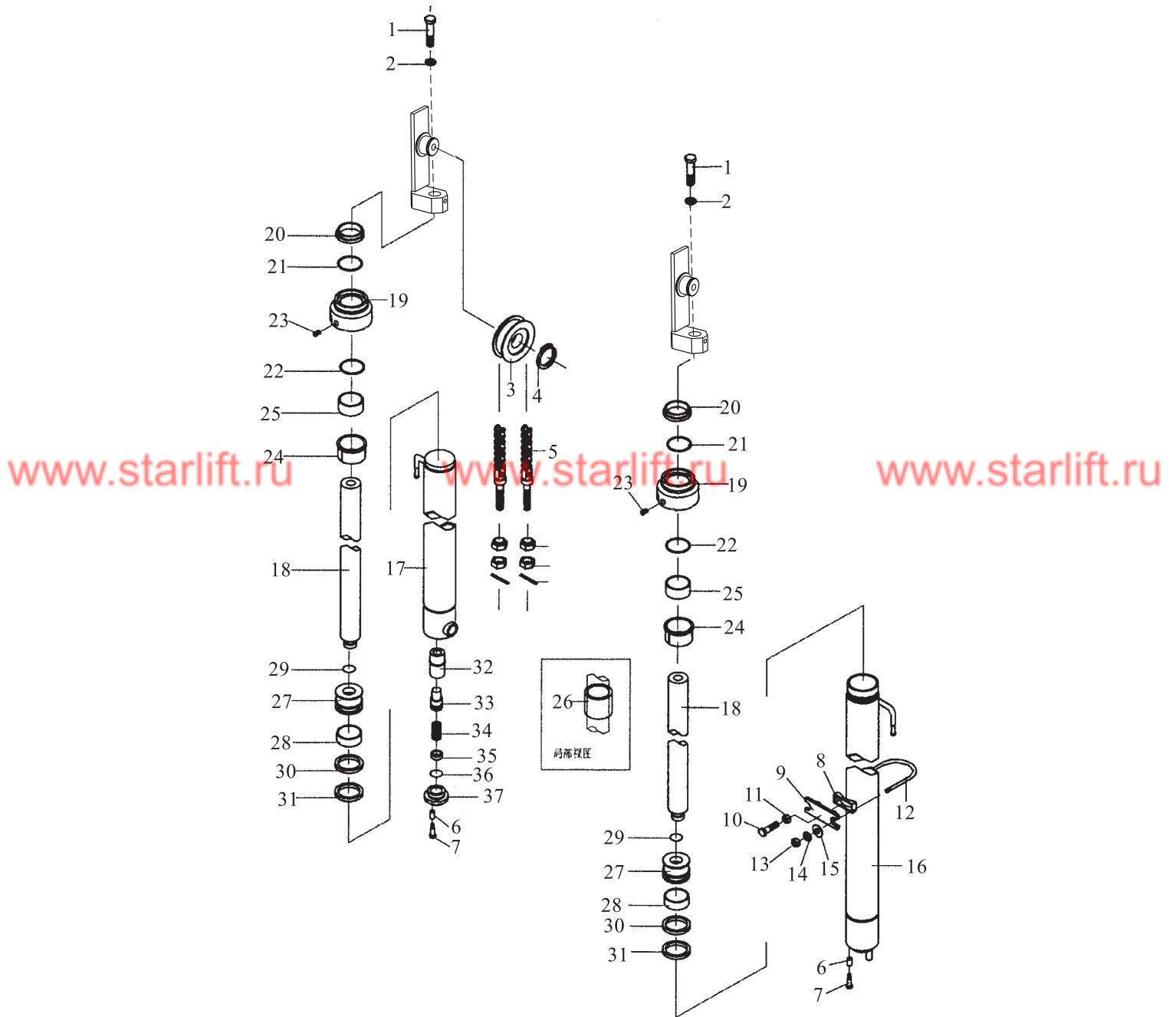

后起升油缸(三节全自由)

Rear Lift Cylinder (Full Free 3-Stage Mast KZM)

序号 Item	零件号 Part No	零部件名称 Description	数量 Q'ty	备注 Remark
17	A30A4-10602	右缸体 Cylinder R.H.	1	3t
	A20A4-10602	右缸体 Cylinder R.H.	1	2-2.5t
18	A30A4-10603	活塞杆 Piston rod	2	3t
	A20A4-10603	活塞杆 Piston rod	2	2-2.5t
19	A30A4-10604	导向套 Guide,Sleeve	2	3t
	A20A4-10604	导向套 Guide,Sleeve	2	2-2.5t
20	A30A4-10101	防尘圈45×57×7/10 Dust ring	2	3t
	A20A4-10605	防尘圈40×52×7/10 Dust ring	2	2-2.5t
21	A30A4-10102	轴用密封圈45×55×6 Ring	2	3t
	A20A4-10102	轴用密封圈40×50×6 Ring	2	2-2.5t
22	GB/T1235-76	O型密封圈55.6×2.4 O-ring	2	3t
	GB/T1235-76	O型密封圈49.7×2.4 O-ring	2	2-2.5t
23	A30A4-10104	塞子 Plug	2	3t
24	A30A4-10110	衬套 Sleeve	2	3t
25	A30A4-10103	钢背轴承4530 Guide bushing	2	3t
	A20A4-10103	钢背轴承4030 Guide bushing	2	2-2.5t
26	A30A4-10605	调整套 Spacer	2	3t
	A20A4-10606	调整套 Spacer	2	2-2.5t
27	A30A4-10113	活塞 Piston	2	3t
	A20A4-10113	活塞 Piston	2	2-2.5t

后起升油缸(三节全自由)

Rear Lift Cylinder (Full Free 3-Stage Mast KZM)

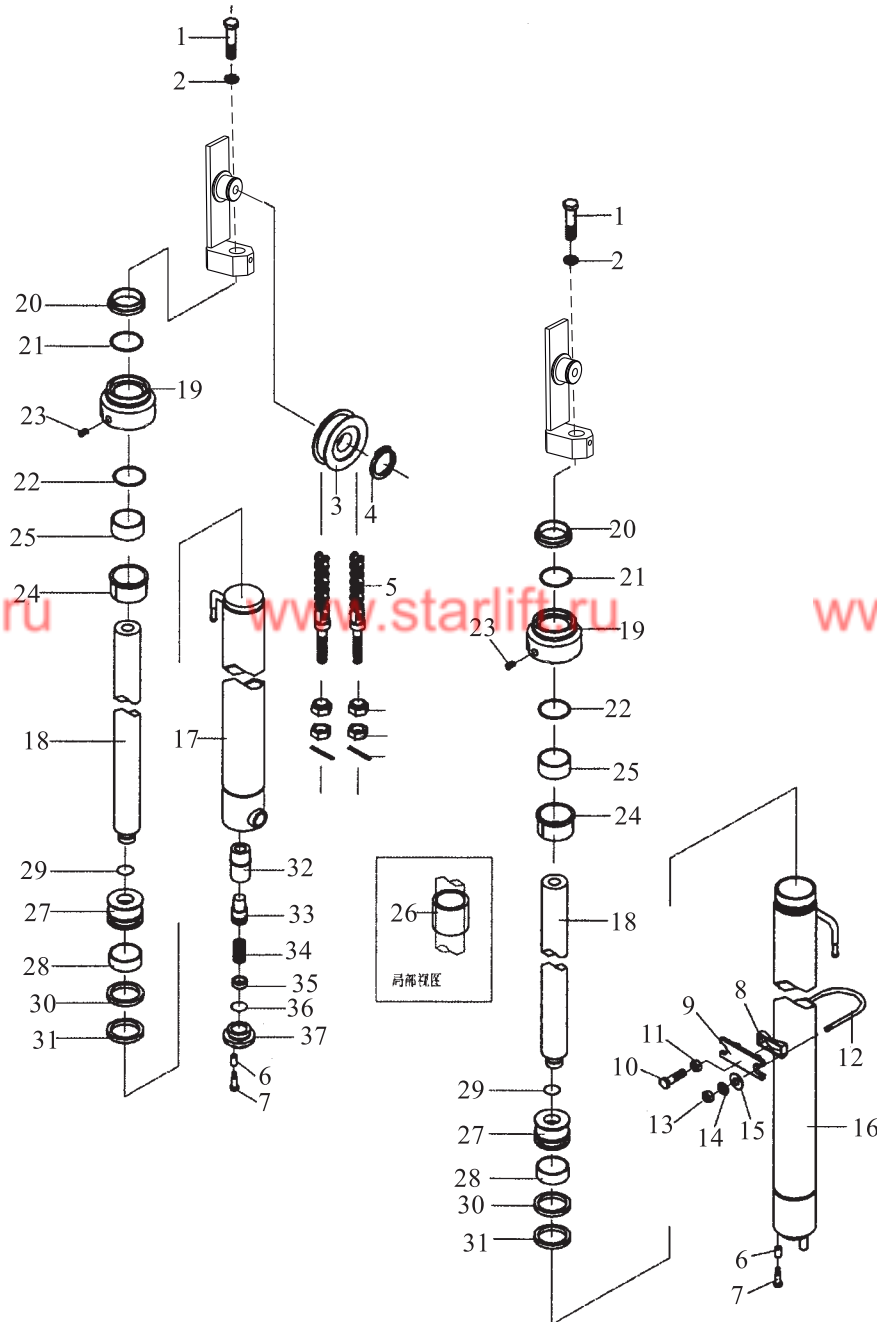

后起升油缸(三节全自由)

Rear Lift Cylinder (Full Free 3-Stage Mast KZM)

序号 Item	零件号 Part No	零部件名称 Description	数量 Q'ty	备注 Remark
28	A30A4-10105	支承环56×20×2.5 Wearing	2	3t
	A20A4-10105	支承环50×20×2.5 Wearing	2	2-2.5t
29	A30A4-10108	钢丝挡圈 Snap ring	2	
30	A30A4-10106	挡片56×45×3 Ring, back up	2	3t
	A20A4-10106	挡片50×40×3 Ring, back up	2	2-2.5t
31	A30A4-10107	U型密封圈56×45×7 U-ring	2	3t
	A20A4-10107	孔用密封圈50×40×6 Ring	2	2-2.5t
32	A30A4-10606	阀套 Sleeve	1	3t
	A20A4-10607	阀套 Sleeve	1	2-2.5t
33	A30A4-10607	阀芯 Spool	1	3t
	A20A4-10608	阀芯 Spool	1	2-2.5t
34	A30A4-10608	弹簧 Spring	1	3t
	A20A4-10609	弹簧 Spring	1	2-2.5t
35	A30A4-10609	弹簧座 Seat, spring	1	3t
	A20A4-10610	弹簧座 Seat, spring	1	2-2.5t
36	GB/T1235-76	O型密封圈40×3.5 O-ring	1	
37	A30A4-10610	底座 Seat, valve	1	3t
	A20A4-10611	底座 Seat, valve	1	2-2.5t