

13—1. 燃油滤清器结合组(一) FUEL FILTER ASSEMBLY(1)

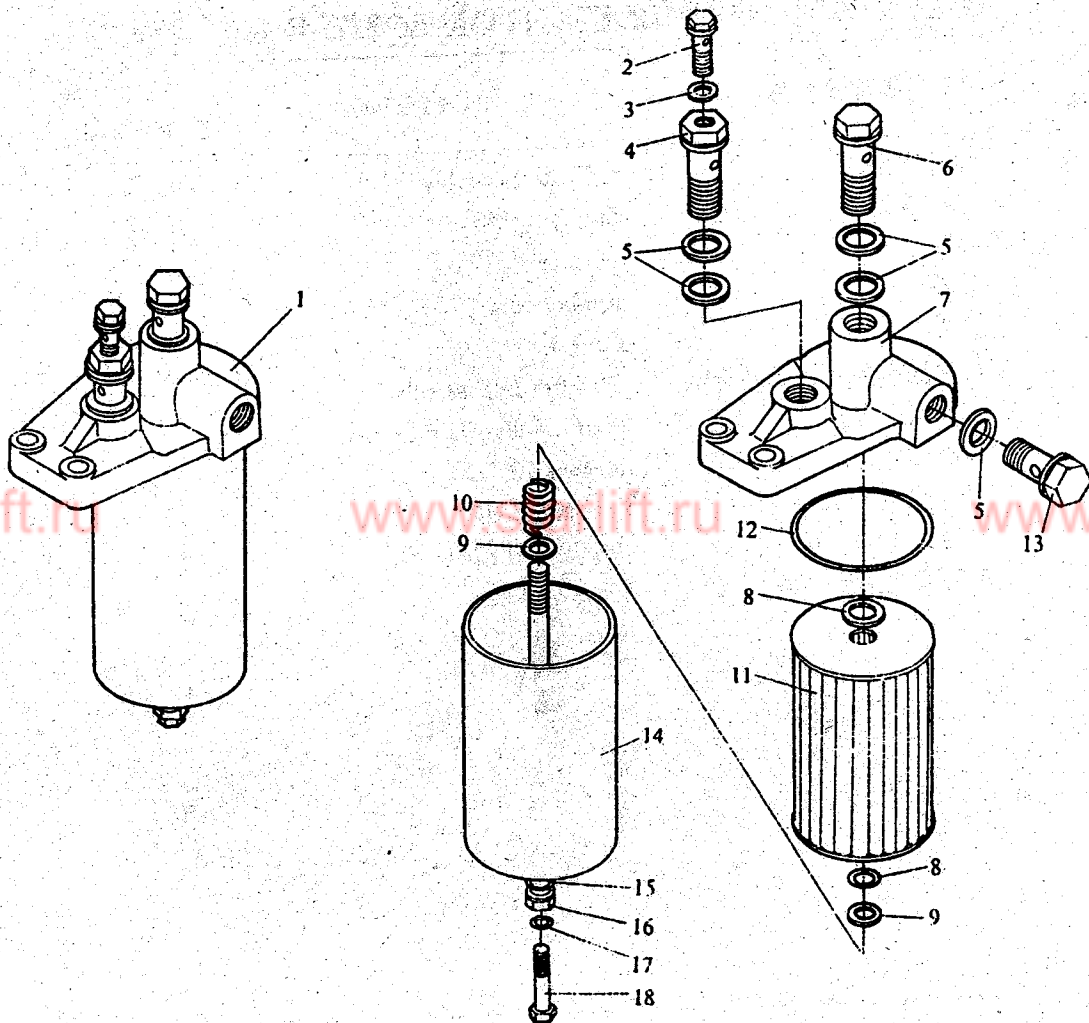

13—1. 燃油滤清器结合组(一) FUEL FILTER ASSEMBLY(1)

序号 No.	零部件号 Part Number	零部件名称	Part Name	数量 Quantity	备注 Remark
1	6102A 15 00	燃油滤清器结合组	Fuel filter assembly	1	
2	6102 15 01	回油螺钉	Fuel return screw	1	
3	6102 15 02	垫片	Washer	2	
4	6102 15 10	逆止阀结合部	Check valve assembly	1	
5	6102 15 03	组合密封垫圈	Washer	6	
6	6102 15 15	空心螺钉	Hollow screw	1	
7	6102A 15 04	滤座	Seat	1	
8	6102 15 07	胶垫	Gasket	2	
9	6102 15 13	垫圈	Washer	2	
10	6102 15 08	弹簧	Spring	1	
11	6102 15 20	滤芯结合部	Filter element assembly	1	
12	6102 15 05	橡胶垫圈	Gasket	1	
13	6102 15 15	空心螺钉	Hollow screw	1	
14	6102 15 14	外壳	Case	1	
15	6102 15 09	O形橡胶圈	O-ring	1	
16	6102 15 06	拉杆	Pull rod	1	
17	6102 15 11	O形橡胶圈	O-ring	1	
18	6102 15 12	螺钉	Screw	1	

13—2. 燃油滤清器结合组(二) (BQ25d、BQ26b、BQ28b 用)
FUEL FILTER ASSEMBLY(2) (FOR BQ25d、BQ26b、BQ28b)

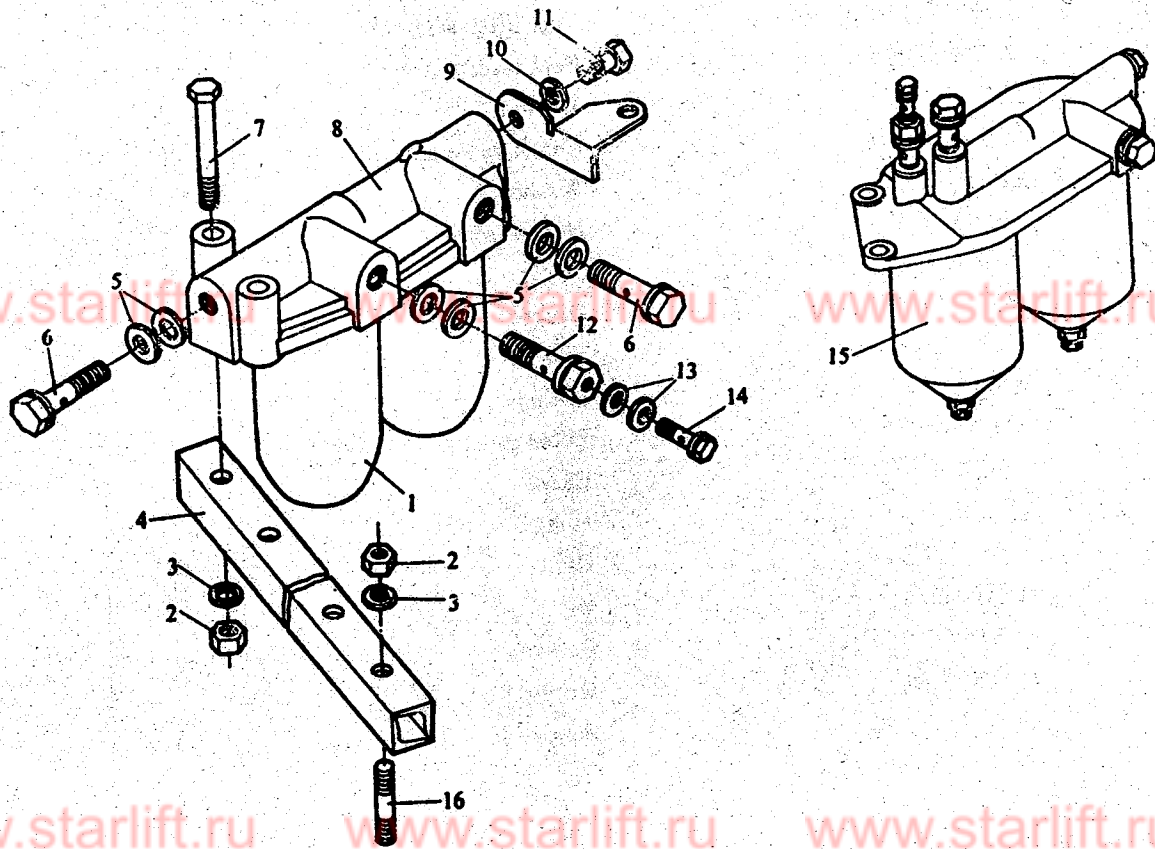

13—2. 燃油滤清器结合组(二)(BQ25d、BQ26b、BQ28b 用)
 FUEL FILTER ASSEMBLY(2) (FOR BQ25d、BQ26b、BQ28b)

序号 No.	零部件号 Part Number	零部件名称	Part Name	数量 Quantity	备注 Remark
	6102B 15 00	柴油滤清器结合组	Fuel oil filter assembly	1	BQ25d 用 For BQ25d
1	CX0710A	滤罐结合部	Filter housing	2	BQ25d 用 For BQ25d
2	GB39—88	螺母 M10	Nut M10	4	
3	GB859—87	垫圈 10	Washer 10	2	
4	6102B 15 27	支承杆	Supporting rod	1	BQ25d 用 For BQ25d
5	6102 15 03	组合密封垫圈	Multiple sealing washer	6	
6	6102 15 15	空心螺钉	Hollow screw	2	
7	GB5782—86	螺栓 M10×75	Bolt M10×75	2	BQ25d 用 For BQ25d
8	6102B 15 04	滤座	Filter seat	1	BQ25d 用 For BQ25d
9	6102B 15 28A	支承板	Supporting plate	1	BQ25d 用 For BQ25d
10	GB859—89	垫圈 10	Washer 10	1	
11	GB5783—86	螺栓 M10×20	Bolt M10×20	1	
12	6102 15 10	逆止阀结合部	Check valve	1	
13	6102 15 02	垫片	Gasket	2	
14	6102 15 01	回油螺钉	Fuel return screw	1	
15	2CS0712A	柴油滤清器总成	Fuel oil filter assembly	1	BQ26b、BQ28b 用 For BQ26b、28b
16	GB898—88	螺柱 GM 10—M10×40	Stud GM10—M10×40	2	